

**NEW YORK STATE THRUWAY AUTHORITY
DEPARTMENT OF ENGINEERING**

**ALBANY, NY
FEBRUARY 11, 2026**

**AMENDMENT NO. 1
TO**

**CONTRACT TAN 26-14
D215082
PAVEMENT REHABILITATION AND MISCELLANEOUS
WORK ON I-190, NIAGARA THRUWAY
FROM MP N0.7 TO MP N4.2
IN THE BUFFALO DIVISION
OF THE NEW YORK STATE THRUWAY
IN ERIE COUNTY**

**IN THE LETTING OF
FEBRUARY 18, 2026**

NOTE: This amendment shall be attached to and become a part of the Proposal for Contract **TAN 26-14**.

NOTICE

For Electronic Bidders, the Project's amended EBSX file will automatically account for any necessary item changes (deletions, changes in quantities, or additions) that this Amendment may describe as being required regarding the project's estimated cost. Instructions to make physical changes to the Project Proposal's bid sheets are intended for "paper" Bidders who choose to submit bids via paper.

Questions and Answers for this project are available from the Authority's website, specifically at: https://content3.thruway.ny.gov/netdata/contractors/documents/d215082_tan26-14_questions-and-answers-02-09-2026.pdf. This document may be updated periodically without formal issuance of an Amendment. Prospective bidders are advised to revisit this link weekly and before proposals are due, for any possible additional questions and answers information.

PROPOSAL

1. The Letting Date for this project has been rescheduled to February 25, 2026. All Bidders are authorized to **CHANGE** the Contract Proposal cover to read: **LETTING OF FEBRUARY 25, 2026**.

2. **CHANGE** the estimated quantity for the following Item(s):

<u>Contract Proposal Page</u>	<u>Item No.</u>	<u>Description</u>	<u>Unit</u>	<u>Initial Estimated Quantity</u>	<u>Revised Estimated Quantity</u>
231	203.07	Select Granular Fill	CY	440	450
231	206.0201	Trench and Culvert Excavation	CY	1,460	1,540
233	404.1959	19 F9 Binder Course Asphalt, 50 Series Compaction	TON	4,910	4,960
233	404.3789	37.5 F9 Base Course Asphalt, 80 Series Compaction	TON	2,219	2,490
233	407.01040009	Non-Tracking Tack Coat	GAL	43,640	43,660
234	502.9001 18	Clean and Fill Cracks and Joints Portland Cement Concrete (PCC) Pavement ASTM D6690 Type IV	LF	85,872	85,844
234	510.00120018	Portland Cement Concrete (PCC) for Full Depth Pavement Repairs - Unreinforced, PEM Friction Type 2	CY	5,920	5,740
235	510.81000018	Drill and Anchor Dowels for PCC Pavement Repairs	EA	12,770	12,250
235	510.81100018	Drill and Anchor Ties for PCC Pavement Repairs	EA	670	650
235	510.91000018	Transverse Joints for PCC Pavement Repairs	LF	6,500	6,280
235	552.17	Shields and Shoring	SF	1,475	2,100

The “paper” Bidder shall **CROSS OUT** the estimated quantity shown for these items in the Contract Proposal, **WRITE IN** the revised estimated quantity, and submit its bid based on the noted changes. If the Bidder fails to make these changes, the Authority will do so and adjust the BID AMOUNT for the items and TOTAL BID, accordingly.

3. **ADD** the following Item:

<u>Contract Proposal Page</u>	<u>Item No.</u>	<u>Description</u>	<u>Unit</u>	<u>Estimated Quantity</u>
255A-A1	208.5301	Stormwater Treatment System SWTD - Maximum Treatment Flow Rate Over 2.0 cfs up to 2.8 cfs	EA	2

The “paper” Bidder must **RETURN THE ATTACHED PAGE 255A-A1** with its bid for this Contract.

PLANS

4. **DELETE** Drawing Number MD-1, Sheet 190 of 421, and **SUBSTITUTE** with the attached Drawing Number MD-1, Sheet 190-A1 of 421. Added a new Note 4. under “General Notes”.

5. **DELETE** Drawing Number MD-12, Sheet 201 of 421, and **SUBSTITUTE** with the attached Drawing Number MD-12, Sheet 201-A1 of 421. A required Water Quality Volume Table has been added, the name of the (Item 208.2501) detail has been changed to Stormwater Treatment System Details, it now also references the new Item 208.5301, and the Elevation View A-A dimensions (now labeled as X and Y) have been changed.
6. **DELETE** Drawing Number MT-6, Sheet 207 of 421, and **SUBSTITUTE** with the attached Drawing Number MT-6, Sheet 207-A1 of 421. Changed table due to the addition of stormwater treatment units.
7. **DELETE** Drawing Number MT-10, Sheet 211 of 421, and **SUBSTITUTE** with the attached Drawing Number MT-10, Sheet 211-A1 of 421. Changed table due to the addition of stormwater treatment units.
8. **DELETE** Drawing Number MT-15, Sheet 216 of 421, and **SUBSTITUTE** with the attached Drawing Number MT-15, Sheet 216-A1 of 421. Changed table due to the addition of stormwater treatment units.
9. **DELETE** Drawing Number CPRT-5, Sheet 252 of 421, and **SUBSTITUTE** with the attached Drawing Number CPRT-5, Sheet 252-A1 of 421. Changed Full Depth Repair material from concrete to asphalt in various areas.
10. **DELETE** Drawing Number CPRT-6, Sheet 253 of 421, and **SUBSTITUTE** with the attached Drawing Number CPRT-6, Sheet 253-A1 of 421. Changed Full Depth Repair material from concrete to asphalt in various areas.
11. **DELETE** Drawing Number CPRT-7, Sheet 254 of 421, and **SUBSTITUTE** with the attached Drawing Number CPRT-7, Sheet 254-A1 of 421. Changed Full Depth Repair material from concrete to asphalt in various areas.
12. **DELETE** Drawing Number CPRT-15, Sheet 262 of 421, and **SUBSTITUTE** with the attached Drawing Number CPRT-15, Sheet 262-A1 of 421. Changed Full Depth Repair material from concrete to asphalt in various areas.
13. **DELETE** Drawing Number CPRT-19, Sheet 266 of 421, and **SUBSTITUTE** with the attached Drawing Number CPRT-19, Sheet 266-A1 of 421. Changed Full Depth Repair material from concrete to asphalt in various areas.
14. **DELETE** Drawing Number BP-8, Sheet 398 of 421, and **SUBSTITUTE** with the attached Drawing Number BP-8, Sheet 398-A1 of 421. The plan view for MP 902.99 Bridge over Selkirk Street and RR Yard and protective sealing table have been reorganized to now accommodate six new Expansion Joint Opening Tables for each Pier of the bridge.

The Bidder **MUST** complete Page **270** of the Proposal acknowledging receipt of this amendment. If the Bidder fails to complete the “Amendment Acknowledgement” sheet, his bid could be declared informal thereby delaying award of the contract.

PLEASE BE GOVERNED ACCORDINGLY WHEN SUBMITTING BIDS.

Brent E. Howard, P.E.
Chief Engineer



**Thruway
Authority**

02/10/2026 9:15:53 AM

AASHTOWare Project™ Version 5.02.04 Revision 045

Proposal Schedule of Items

Proposal ID: D215082

Project(s): B05073A

Contractor: _____

SECTION:

Alt Set ID:

Alt Mbr ID:

Proposal Line Number	Item ID Description	Approximate Quantity and Units	Unit Price		Bid Amount	
			Dollars	Cents	Dollars	Cents
0500	208.5301 STORMWATER TREATMENT SYSTEM SWTD - MAXIMUM TREATMENT FLOW RATE OVER 2.0 CFS UP TO 2.8 CFS	2.000 EACH	_____	_____	_____	_____
Section:			Total:		_____	

THIS SHEET SUPERSEDES SHEET 190
IN ITS ENTIRETY

GENERAL NOTES:

- SAW CUTTING - LAYOUT & SAWING:**
THE CONTRACTOR SHALL MARK OUT CLEARLY THE SAW CUT BOUNDARY LINE ACCORDING TO THE PAVEMENT REPAIR TABLES AND THE TYPICAL PAVEMENT REMOVAL PLANS SHOWN ON THIS SHEET.
THE CONTRACTOR MAY MAKE FULL DEPTH SAW CUTS A MAXIMUM OF 24 HOURS IN ADVANCE OF THE REMOVAL OPERATION. PAVEMENT REMOVAL OPERATIONS SHALL BEGIN 24 HOURS AFTER THE FULL DEPTH SAW CUT. ANY PAVEMENT DAMAGE RESULTING FROM FAILING TO BEGIN REMOVAL OPERATIONS AS SPECIFIED ABOVE SHALL BE REPAIRED AT NO COST TO THE AUTHORITY AND IN A MANNER ACCEPTABLE TO THE ENGINEER.
- DAMAGE AFTER SAWCUTTING:**
ONCE THE SAWCUT IS MADE, THE CONTRACTOR SHALL PROTECT THE SAW CUT EDGE FROM DAMAGE. DAMAGE TO THE SAW CUT EDGE CAUSED BY THE CONTRACTOR'S OPERATION, AS DETERMINED BY THE ENGINEER, SHALL REQUIRE THE CONTRACTOR TO RE-CUT THE BOUNDARY LINE AT A NEW LOCATION OR AS DETERMINED BY THE ENGINEER.
THE BOUNDARY LINE SHALL BE RE-CUT 2 INCHES FROM THE DAMAGED EDGE. IF THE DAMAGE CAN NOT BE REMOVED BY RE-CUTTING THE BOUNDARY LINE 2 INCHES AWAY, THE ENGINEER WILL DETERMINE THE LOCATION OF THE DAMAGE REMOVAL LIMITS. ALL ADDITIONAL WORK NEEDED TO REPAIR DAMAGED AREAS SHALL BE COMPLETED BY THE CONTRACTOR AT NO COST TO THE AUTHORITY.
THE CONTRACTOR SHALL NOTE THAT THE ENGINEER MAY BE REQUIRED TO SIGNIFICANTLY INCREASE THE SIZE OF PAVEMENT REPAIR LIMITS IF DAMAGE OCCURS, TO MAINTAIN SIMILAR PAVEMENT SLAB SIZES.
- IN AREAS WHERE THE EXISTING SUBBASE IS DETERMINED BY THE ENGINEER TO BE UNSUITABLE, THE EXISTING SUBBASE SHALL BE UNDERCUT AND BACKFILLED AS SHOWN IN DETAIL.**
- FULL DEPTH ASPHALT REPAIRS SHALL CONSIST OF 4" OF ITEM 404.1959 - BINDER COURSE ASPHALT AND 6" OF ITEM 404.3789 - BASE COURSE ASPHALT. TACK COAT SHALL BE APPLIED BETWEEN THE LIFTS AND ALONG THE VERTICAL EDGES OF THE SURROUNDING CONCRETE PAVEMENT PANELS TO REMAIN.**

JOINT NOTES:

- ALL JOINTS CONSTRUCTED SHALL MATCH THE EXISTING JOINT LAYOUT AS PRACTICABLE AT THE LOCATIONS SHOWN ACCORDING TO REPAIR PLANS OR AS ORDERED BY THE ENGINEER. ADDITION OF JOINTS OTHER THAN AS OUTLINED ABOVE WILL NOT BE ALLOWED.**
- ALL JOINT SAWCUTS SHALL BE PERPENDICULAR TO THE PAVEMENT SURFACE AND PARALLEL TO THE EXISTING JOINT PLAN. ANY SAWCUTS NOT CONFORMING, AS DETERMINED BY THE ENGINEER, TO THE DETAILS AND NOTES IN THESE PLANS WILL BE REJECTED BY THE ENGINEER. NO PAYMENT WILL BE MADE FOR REJECTED SAWCUTS.**
- LONGITUDINAL JOINT TIES**
LONGITUDINAL JOINT TIES SHALL BE USED ONLY ON PAVEMENT REPAIRS WITH FULL LENGTH SLABS, WHEN NEW TRANSVERSE JOINTS MATCH EXISTING.
WHEN ALLOWED BY THE ENGINEER, HAND-HELD DRILLS MAY BE USED IF THE DRILL SPECIFIED IN ITEM 510.8100018 CANNOT BE POSITIONED WITHOUT BEING IN CONFLICT WITH THE WORK ZONE TRAFFIC CONTROL.
LONGITUDINAL JOINT TIES SHALL BE USED WHEN PAVEMENT REPAIRS ARE TO BE COMPLETED FOR MORE THAN ONE LANE OF THE PAVEMENT AND THE LANE OF THE PAVEMENT AND THE REPAIRS HAVE THE SAME TRANSVERSE JOINT LOCATION.
NEW LONGITUDINAL JOINTS SHALL BE CONSTRUCTED USING ITEM 510.91100018 - LONGITUDINAL JOINTS. SEE NYS DOT STANDARD SHEETS 502-03, 502-04 AND 502-06 FOR DETAILS.
- CONSTRUCTING NEW LONGITUDINAL JOINTS**
THE LONGITUDINAL JOINT TIES SHALL MEET THE REQUIREMENTS OF ITEM 510.91100018 - LONGITUDINAL JOINTS. PLACEMENT AND SPACING OF THE JOINT TIES SHALL CONFORM TO THE STANDARD SPECIFICATION. THE UNIT PRICE BID FOR THIS ITEM SHALL INCLUDE THE COST OF ALL WORK TO COMPLETE THE REPAIRS, AS DETAILED IN THESE PLANS.
- CONSTRUCTING NEW TRANSVERSE JOINTS**
WHEN MULTIPLE SLABS ARE BEING REPLACED FOR ONE LANE, DRILL AND ANCHOR TRANSVERSE DOWEL BARS TO TIE INTO THE EXISTING CONCRETE AT THE BEGINNING AND END, ITEM 510.8100018. THE TRANSVERSE JOINTS BETWEEN SLABS AND MID SPAN JOINTS SHALL BE CONSTRUCTED USING HINGE AND TRANSVERSE JOINTS, ITEM 510.9100018, RESPECTIVELY. SEE NYS DOT STANDARD SHEETS 502-05 & 502-06 FOR DETAILS. NEW JOINTS SHALL BE FILLED USING ITEM 502.90010018.

DOWEL BAR RETROFIT NOTES:

- THE CONTRACTOR SHALL RETRO-FIT CRACKS ACCORDING TO THE PAVEMENT REPAIR TABLES OR AS DIRECTED BY THE ENGINEER. PRIOR TO SAWCUTTING, THE CONTRACTOR SHALL MARK OUT THE BAR LOCATIONS ACCORDING TO THE DETAILS SHOWN ON THIS SHEET. THE CONTRACTOR MAY BEGIN SAWCUTTING AFTER ACCEPTANCE OF THE MARK OUT BY THE ENGINEER.
- WHEN RETRO-FITTING CRACKS THAT TERMINATE WITHIN A SLAB AND NOT AT AN EXISTING JOINT OR EDGE OF SLAB, THE CONTRACTOR SHALL DRILL A HOLE 25% LARGER THAN THE CRACK WIDTH, AS DETERMINED BY THE ENGINEER, FOR THE FULL DEPTH OF THE SLAB AND FILL THIS HOLE WITH THE SAME ANCHORING MATERIAL (701-07) BEING USED FOR OTHER WORK ON THE PROJECT.
THE UNIT PRICE BID FOR ITEM 502.70010018 RETRO-FIT DOWELS IN PCC PAVEMENT SHALL INCLUDE THE COST TO DRILL AND FILL THIS HOLE WITH 701-07 ANCHORING MATERIAL AT ANY CRACK LOCATION AS DESCRIBED ABOVE OR WHERE ORDERED BY THE ENGINEER.
- ANY RETRO-FIT INSTALLATION THAT DOES NOT CONFORM TO THE DETAILS OR THE SPECIFICATION SHALL BE REJECTED AND THE CONTRACTOR SHALL REPLACE THE REJECTED RETRO-FIT AS DIRECTED BY THE ENGINEER. NO PAYMENT WILL BE MADE FOR ANY LOCATION REJECTED BY THE ENGINEER.
- CLEAN AND FILL CRACKS THAT ARE EQUAL TO OR GREATER THAN 1/8"

PARTIAL DEPTH NOTES:

- THE CONTRACTOR SHALL NOTE THAT THE TYPICAL REMOVAL PLAN SHOWS COMMON PATTERNS AND NOT ALL FIELD CONDITIONS MAY BE SHOWN. THE ENGINEER WILL MAKE ANY CHANGES TO REPAIR SIZES AND TYPES AS NEEDED.
- THE CONTRACTOR SHALL MARK OUT CLEARLY THE SAW CUT BOUNDARY LINE ACCORDING TO THE PAVEMENT REPAIR TABLES AND THE TYPICAL PAVEMENT REMOVAL PLAN.
IF, IN THE OPINION OF THE ENGINEER, THE REMOVAL MARK OUT BOUNDARY BECOMES EXCESSIVE, THEY WILL INFORM THE CONTRACTOR THAT THE REPAIR WILL BE MADE AS A FULL DEPTH REPAIR OR THE ENGINEER WILL INFORM THE CONTRACTOR THAT THE MARK OUT IS ACCEPTABLE AND THE CONCRETE REMOVAL CAN BEGIN.
THE COST FOR ALL SAWCUTTING ALONG WITH THE REMOVAL AND DISPOSAL OF THE CONCRETE SHALL BE INCLUDED IN THE PRICE BID FOR ITEM 511.70000018 CONCRETE REPAIR PARTIAL DEPTH.
- DAMAGE AFTER SAWCUTTING:**
ONCE THE SAW CUT IS MADE THE CONTRACTOR SHALL PROTECT THE SAW CUT EDGE FROM DAMAGE. DAMAGE TO THE SAW CUT EDGE CAUSED BY THE CONTRACTOR'S OPERATIONS, AS DETERMINED BY THE ENGINEER, SHALL REQUIRE THE CONTRACTOR TO RE-CUT THE BOUNDARY LINE AT A NEW LOCATION AS DETERMINED BY THE ENGINEER.
THE BOUNDARY LINE SHALL BE RE-CUT A MINIMUM OF 2" FROM THE DAMAGED EDGE. THE BOUNDARY LINE RE-CUT SHALL REMOVE ALL OVER SAWING MADE TO MAKE THE REPAIR. ALL ADDITIONAL WORK NEEDED TO REMOVE DAMAGED AREAS SHALL BE COMPLETED BY THE CONTRACTOR AT NO COST TO THE AUTHORITY.
- REPAIR BOTTOM:**
USING CHIPPING HAMMERS, THE CONTRACTOR SHALL LEVEL THE BOTTOM OF THE REPAIR AREA TO OBTAIN AN EVEN THICKNESS FOR THE CONCRETE REPAIR MATERIAL. ALL CONCRETE REMOVAL SHALL BE DONE TO THE SATISFACTION OF THE ENGINEER.
- OVER SAWING OF REPAIR:**
THE CONTRACTOR SHALL OVER SAW THE PARTIAL REPAIR LIMITS TO COMPLETE THE REMOVAL OF CONCRETE. THE OVER SAWEED AREAS SHALL BE CLEANED ACCORDING TO THE REQUIREMENTS FOR ITEM 511.70000018 PCC PARTIAL DEPTH REPAIRS. THE OVER SAWEED AREAS SHALL BE FILLED WITH ANCHORING MATERIAL MEETING THE REQUIREMENTS OF SECTION 701-07 OF THE STANDARD SPECIFICATION. THE COST TO COMPLETE THIS WORK SHALL BE INCLUDED IN THE PRICE BID FOR ITEM 511.70000018.
- AT NO TIME SHALL THE CONTRACTOR ALLOW PATCHING MATERIAL TO FLOW INTO OR CROSS A CRACK. CONTRACTOR SHALL NOT ALLOW PATCHING MATERIAL TO FLOW INTO SHOULDER AREAS.

CLEAN AND FILL ALL EXISTING LONGITUDINAL AND TRANSVERSE JOINTS ON MAINLINE AND INTERCHANGE RAMPS. REFER TO NOTES "D" AND "F" FOR SAWING AND SEALING NEW LONGITUDINAL AND TRANSVERSE JOINTS IN ACCORDANCE WITH NYS DOT STANDARD SHEETS.

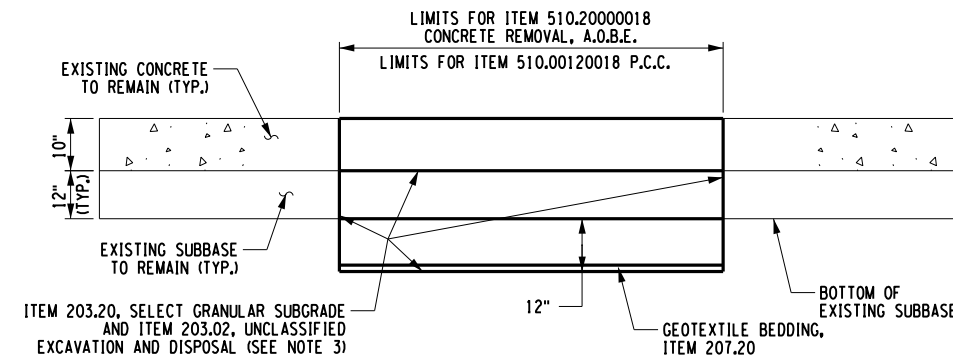
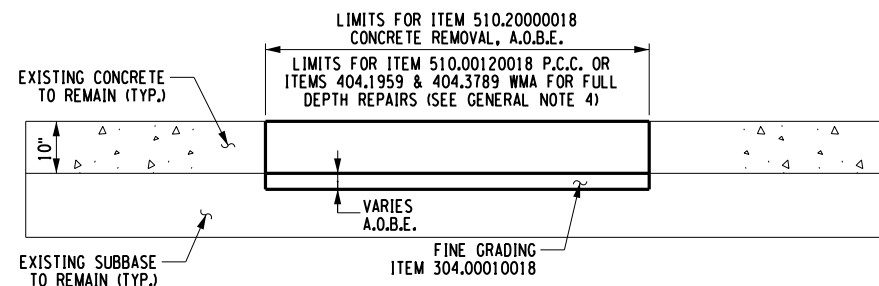

ALTERED ON:	AFFIXED ON: 2/5/2026
SIGNATURE: STAMP:	SIGNATURE: STAMP:

IT IS A VIOLATION OF LAW FOR ANY PERSON, UNLESS THEY ARE ACTING UNDER THE DIRECTION OF A LICENSED PROFESSIONAL ENGINEER, ARCHITECT, LANDSCAPE ARCHITECT, OR LAND SURVEYOR, TO ALTER AN ITEM IN ANY WAY. IF AN ITEM BEARING THE STAMP OF A LICENSED PROFESSIONAL IS ALTERED, THE ALTERING ENGINEER, ARCHITECT, LANDSCAPE ARCHITECT, OR LAND SURVEYOR SHALL STAMP THE DOCUMENT AND INCLUDE THE NOTATION "ALTERED BY" FOLLOWED BY THEIR SIGNATURE, THE DATE OF SUCH ALTERATION, AND A SPECIFIC DESCRIPTION OF THE ALTERATION.

REVISIONS			
DATE	DESCRIPTION	BY	SYM.

TITLE OF PROJECT I-190 HIGHWAY REHABILITATION	CONTRACT NUMBER: TAN 26-14
LOCATION OF PROJECT I-190 NIAGARA THRUWAY MP 900.7 TO MP 904.2	DATE: FEB. 2026
TITLE OF DRAWING CAST-IN-PLACE MISCELLANEOUS FULL DEPTH REPAIR DETAILS	DRAWING NUMBER: MD-1

CHECKED BY: J. KLEINMANN
 DRAFTED BY: P. AMICONE
 CHECKED BY: J. KLEINMANN
 DESIGNED BY: P. AMICONE
 DESIGN SUPERVISOR: D. MARSH

THIS SHEET SUPERSEDES SHEET 201 IN ITS ENTIRETY

CHECKED BY: J. KLEINMANN

DRAFTED BY: N. HOY

CHECKED BY: J. KLEINMANN

DESIGNED BY: P. THOMPSON

DESIGN SUPERVISOR: D. MARSH

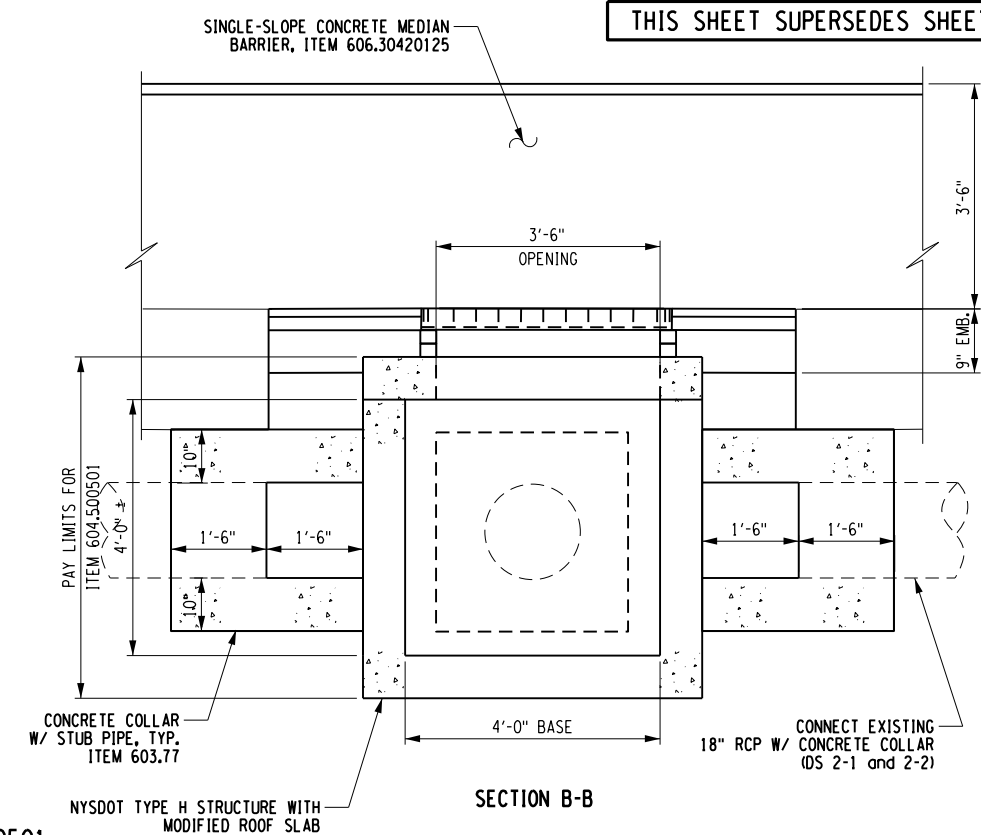
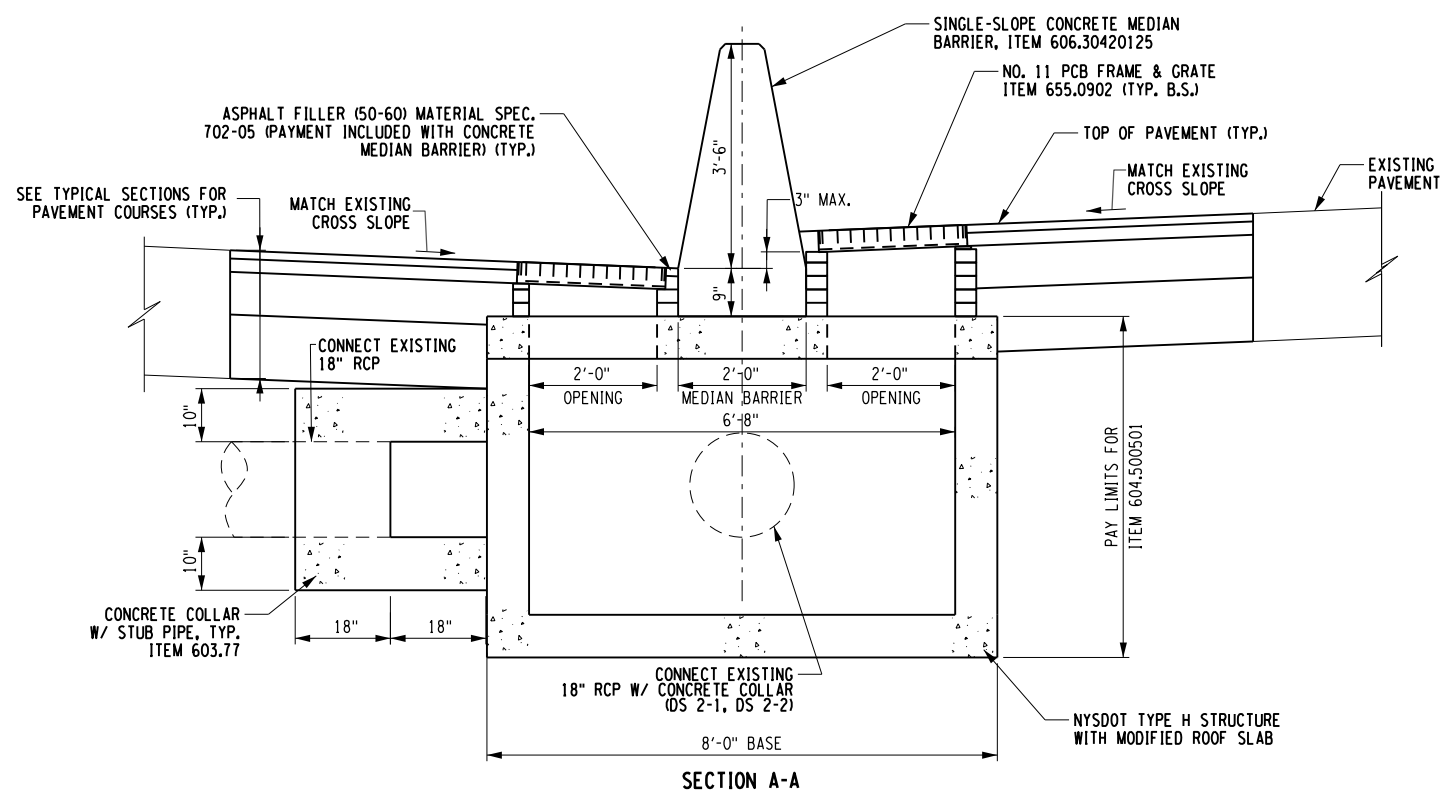

SPECIAL DRAINAGE STRUCTURE - ITEM 604.500501
NYS DOT TYPE H WITH DOUBLE NO. 11 PCB FRAME & GRATE
 (APPLIES TO DS 2-1 AND DS 2-2)
 N.T.S.

WATER QUALITY VOLUME			
STRUCTURE	DS 7-18	DS 21-11	DS 30-11
NYS DOT ITEM NUMBER	208.5301	208.5301	208.5201
RAINFALL EVENT NUMBER	P 2.10	0.99	1.00
IMPERVIOUS COVER	I 22%	71%	100%
AREA	2.15 ACRES	2.20 ACRES	0.57 ACRES
WATER QUALITY VOLUME (WQV)	0.031 ACRE-FEET	0.123 ACRE-FEET	0.037 ACRE-FEET
WQV FLOW RATE (PEAK DISCHARGE)	2.22 CFS	2.01 CFS	0.64 CFS

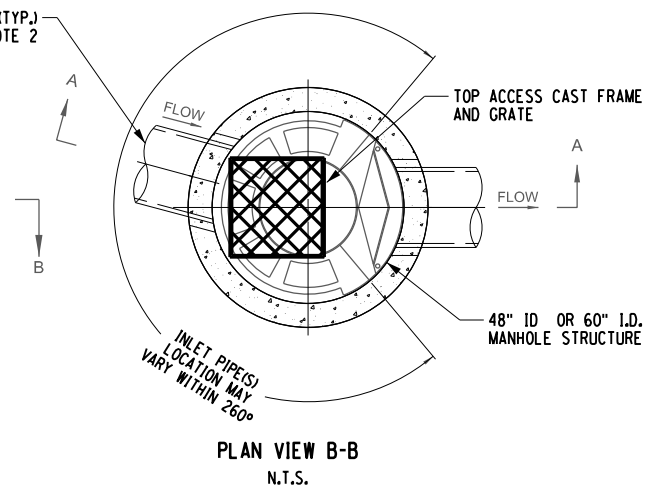
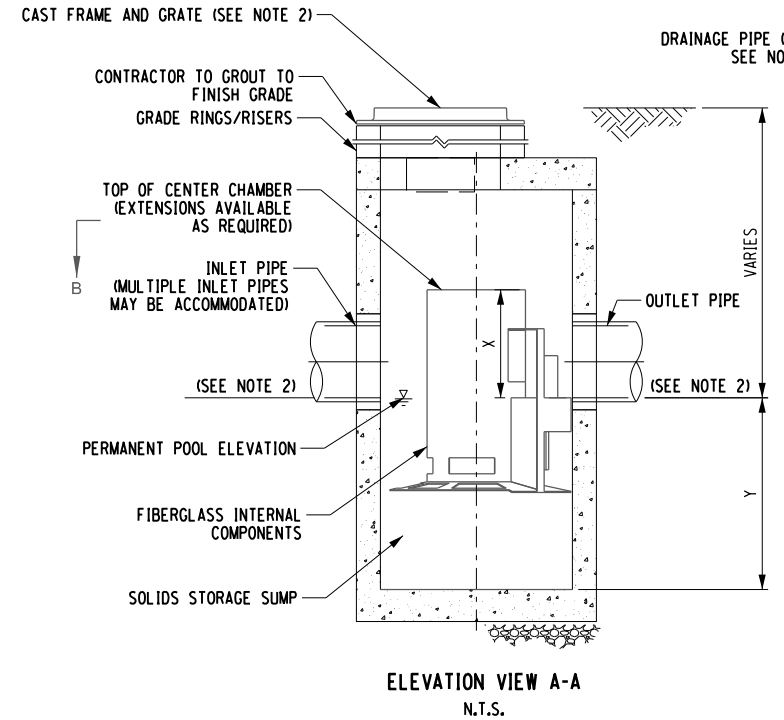

DIMENSIONS		
DIMENSION	DS 30-11	DS 7-18 & DS 21-11
DIAMETER	48"	60"
X	2'-3"	2'-10"
Y	4'-0"	4'-6"

- NOTES:
1. THE STORMWATER TREATMENT SYSTEM SHALL BE A CONTECH CASCADE SEPARATOR (CS-5) OR APPROVED EQUAL. ALL MATERIALS PROVIDED UNLESS OTHERWISE NOTED.
 2. CONTRACTOR SHALL VERIFY EXISTING PIPE SIZES AND INVERTS FOR THE PROPOSED STORMWATER TREATMENT UNITS FOR DS 7-18, DS 21-11, AND DS 30-11. SEE DWG MT-15 FOR PROPOSED DRAINAGE INSTALLATION TABLE.

ALTERED ON:	AFFIXED ON: 2/5/2026
SIGNATURE: STAMP:	SIGNATURE: STAMP:

IT IS A VIOLATION OF LAW FOR ANY PERSON, UNLESS THEY ARE ACTING UNDER THE DIRECTION OF A LICENSED PROFESSIONAL ENGINEER, ARCHITECT, LANDSCAPE ARCHITECT, OR LAND SURVEYOR, TO ALTER AN ITEM IN ANY WAY. IF AN ITEM BEARING THE STAMP OF A LICENSED PROFESSIONAL IS ALTERED, THE ALTERING ENGINEER, ARCHITECT, LANDSCAPE ARCHITECT, OR LAND SURVEYOR SHALL STAMP THE DOCUMENT AND INCLUDE THE NOTATION "ALTERED BY" FOLLOWED BY THEIR SIGNATURE, THE DATE OF SUCH ALTERATION, AND A SPECIFIC DESCRIPTION OF THE ALTERATION.

REVISIONS			
DATE	DESCRIPTION	BY	SYM.

	TITLE OF PROJECT I-190 HIGHWAY REHABILITATION	CONTRACT NUMBER: TAN 26-14
	LOCATION OF PROJECT I-190 NIAGARA THRUWAY MP 900.7 TO MP 904.2	DATE: FEB. 2026
	TITLE OF DRAWING MISCELLANEOUS DETAILS	DRAWING NUMBER: MD-12

THIS SHEET SUPERSEDES SHEET 207
IN ITS ENTIRETY

207-A1
421

CHECKED BY: J. KLEINMANN

DRAFTED BY: N. HOY

CHECKED BY: J. KLEINMANN

DESIGNED BY: P. THOMPSON

DESIGN SUPERVISOR: D. MARSH

DS #	STATION / OFFSET (FT)	DESCRIPTION OF WORK	PROP T.G. ELEV.	ITEM 604.070501 (EA)	ITEM 604.070502 (EA)	ITEM 604.070503 (EA)	ITEM 604.070504 (EA)	ITEM 621.03 (LF)	ITEM 621.04 (EA)	ITEM 634.07060001 (LF)
DS 6-5	ML 49+23.96 84.4'	CLEAN EXISTING DRAINAGE STRUCTURE AND CLEAN 261 LF OF OUTLET PIPE FROM DS 6-5 TO DS 6-3.	-					261.0	1.0	
DS 6-6	ML 49+30.42 2.7' RT	ADJUST EXISTING FRAME AND GRATE TO PROPOSED FINISHED GRADE.	593.35	1.0						
DS 6-7	ML 49+31.01 3.3' LT	ADJUST EXISTING FRAME AND GRATE TO PROPOSED FINISHED GRADE AND CLEAN 66 LF OF OUTLET PIPE FROM DS 6-4 TO DS 6-8. REMOVE CONDUIT & PATCH WALL (SEE DETAIL ON DWG. MD-4)	593.68	1.0		1.0		66.0		
DS 6-8	ML 49+34.71 69.3' LT	CLEAN EXISTING DRAINAGE STRUCTURE AND CLEAN 275 LF OF OUTLET PIPE FROM DS 6-8 TO DS 6-4.	-					275.0	1.0	
DS 6-9	ML 51+97.65 2.9' RT	ADJUST EXISTING FRAME AND GRATE TO PROPOSED FINISHED GRADE AND CLEAN 75 LF OF OUTLET PIPE FROM DS 6-9 TO DS 6-12.	592.89	1.0				75.0		
DS 6-10	ML 51+99.74 3.2' LT	ADJUST EXISTING FRAME AND GRATE TO PROPOSED FINISHED GRADE. REMOVE CONDUIT & PATCH WALL (SEE DETAIL ON DWG. MD-4)	594.21	1.0		1.0				
DS 6-11	ML 52+01.12 69.3' LT	CLEAN EXISTING DRAINAGE STRUCTURE AND CLEAN 263 LF OF OUTLET PIPE FROM DS 6-11 TO DS 6-8.	-					263.0	1.0	
DS 6-12	ML 52+02.43 75.5' RT	CLEAN EXISTING DRAINAGE STRUCTURE AND CLEAN 283 LF OF OUTLET PIPE FROM DS 6-12 TO DS 6-5.	-					283.0	1.0	
DS 7-1	ML 54+37.24 3.1' LT	ADJUST EXISTING FRAME AND GRATE TO PROPOSED FINISHED GRADE. REMOVE CONDUIT & PATCH WALL (SEE DETAIL ON DWG. MD-4)	593.32	1.0		1.0				
DS 7-2	ML 54+37.85 3.0' RT	ADJUST EXISTING FRAME AND GRATE TO PROPOSED FINISHED GRADE AND CLEAN 75 LF OF OUTLET PIPE FROM DS 7-2 TO DS 7-2.	591.60	1.0				75.0		
DS 7-3	ML 54+34.49 66.1' LT	CLEAN EXISTING DRAINAGE STRUCTURE AND CLEAN 231 LF OF OUTLET PIPE FROM DS 7-3 TO DS 6-11.	-					231.0	1.0	
DS 7-4	ML 54+35.34 77.9' RT	CLEAN EXISTING DRAINAGE STRUCTURE AND CLEAN 236 LF OF OUTLET PIPE FROM DS 7-4 TO DS 6-12.	-					236.0	1.0	
DS 7-5	ML 56+50.49 74.5' RT	CLEAN EXISTING DRAINAGE STRUCTURE AND CLEAN 219 LF OF OUTLET PIPE FROM DS 7-5 TO DS 7-4.	-					219.0	1.0	
DS 7-6	ML 56+43.30 67.6' LT	CLEAN EXISTING DRAINAGE STRUCTURE AND CLEAN 206 LF OF OUTLET PIPE FROM DS 7-6 TO DS 7-3.	-					206.0	1.0	
DS 7-7	ML 56+50.59 3.6' LT	ADJUST EXISTING FRAME AND GRATE TO PROPOSED FINISHED GRADE. REMOVE CONDUIT & PATCH WALL (SEE DETAIL ON DWG. MD-4)	592.48	1.0		1.0				
DS 7-8	ML 56+51.17 2.8' RT	ADJUST EXISTING FRAME AND GRATE TO PROPOSED FINISHED GRADE AND CLEAN 75 LF OF OUTLET PIPE FROM DS 7-8 TO DS 7-5.	591.60	1.0				75.0		
DS 7-9	ML 58+66.98 74.3' RT	CLEAN EXISTING DRAINAGE STRUCTURE AND CLEAN 220 LF OF OUTLET PIPE FROM DS 7-9 TO DS 7-5.	-					220.0	1.0	
DS 7-10	ML 58+77.60 74.0' RT	CLEAN EXISTING DRAINAGE STRUCTURE AND CLEAN 11 LF OF OUTLET PIPE FROM DS 7-10 TO DS 7-9.	-					11.0	1.0	
DS 7-11	ML 58+87.70 2.7' RT	ADJUST EXISTING FRAME AND GRATE TO PROPOSED FINISHED GRADE AND CLEAN 75 LF OF OUTLET PIPE FROM DS 7-11 TO DS 7-10.	589.06	1.0				75.0		
DS 7-12	ML 58+87.71 3.1' LT	ADJUST EXISTING FRAME AND GRATE TO PROPOSED FINISHED GRADE. REMOVE CONDUIT & PATCH WALL (SEE DETAIL ON DWG. MD-4)	591.00	1.0		1.0				

DRAINAGE TABLE PAGE 2 OF 10 CONTINUED

DS #	STATION / OFFSET (FT)	DESCRIPTION OF WORK	PROP T.G. ELEV.	ITEM 604.070501 (EA)	ITEM 604.070502 (EA)	ITEM 604.070503 (EA)	ITEM 604.070504 (EA)	ITEM 621.03 (LF)	ITEM 621.04 (EA)	ITEM 634.07060001 (LF)
DS 7-13	ML 59+04.98 70.4' LT	CLEAN EXISTING DRAINAGE STRUCTURE AND CLEAN 258 LF OF OUTLET PIPE FROM DS 7-13 TO DS 7-6.						258.0	1.0	
DS 7-14	ML 59+21.32 3.6' RT	ADJUST EXISTING FRAME AND GRATE TO PROPOSED FINISHED GRADE AND CLEAN 29 LF OF OUTLET PIPE FROM DS 7-14 TO 7-11.	589.19	1.0				29.0		
DS 7-15	ML 59+36.39 54.1' LT	ADJUST EXISTING FRAME AND GRATE TO PROPOSED FINISHED GRADE AND CLEAN 35 LF OF OUTLET PIPE FROM DS 7-8 TO DS 7-13.	589.91			1.0		35.0		
DS 7-16	ML 59+70 4.9' LT	ADJUST EXISTING FRAME AND GRATE TO PROPOSED FINISHED GRADE. REMOVE CONDUIT & PATCH WALL (SEE DETAIL ON DWG. MD-4)	589.91	1.0			1.0			
DS 7-17	ML 60+17.30 50.5' LT	ADJUST EXISTING FRAME AND GRATE TO PROPOSED FINISHED GRADE AND CLEAN 83 LF OF INLET PIPE FROM DS 8-1 TO DS 7-17 AND 80 LF OF OUTLET PIPE FROM DS 7-17 TO DS 7-15.	589.97				1.0	163.0		
DS 7-18	ML 60+15.42 67.9' RT	CLEAN 77 LF OF INLET PIPE FROM DS 8-2 TO DS 7-18 AND 140 LF OF OUTLET PIPE FROM DS 7-18 TO DS 7-10. SEE PROPOSED DRAINAGE INSTALLATION TABLE ON DWG. MT-15 FOR PROPOSED WORK.	-					217.0	1.0	
DS 7-19	ML 60+36.20 3.0' LT	ADJUST EXISTING FRAME AND GRATE TO PROPOSED FINISHED GRADE. REMOVE CONDUIT & PATCH WALL (SEE DETAIL ON DWG. MD-4)	590.95	1.0			1.0			
DS 7-20	ML 60+36.45 2.5' RT	ADJUST EXISTING FRAME AND GRATE TO PROPOSED FINISHED GRADE AND CLEAN 72 LF OF OUTLET PIPE FROM DS 7-20 TO DS 7-18.	589.37	1.0				72.0		
DS 8-1	ML 60+98.22 75.2' LT	REFER TO DS 7-17.	-							
DS 8-2	ML 60+90.34 79.7' RT	REFER TO DS 7-18					1.0			
DS 8-3	ML 62+86.47 3.0' LT	ADJUST EXISTING FRAME AND GRATE TO PROPOSED FINISHED GRADE AND CLEAN 83 LF OF OUTLET PIPE FROM DS 8-3 TO DS 8-5. REMOVE CONDUIT & PATCH WALL (SEE DETAIL ON DWG. MD-4)	592.55	1.0				83.0		
DS 8-4	ML 62+88.52 2.8' RT	ADJUST EXISTING FRAME AND GRATE TO PROPOSED FINISHED GRADE.	591.41	1.0						
DS 8-5	ML 62+92.08 83.1' LT	REFER TO DS 8-3.	-							
DS 8-6	ML 65+84.13 2.4' RT	ADJUST EXISTING FRAME AND GRATE TO PROPOSED FINISHED GRADE.	593.47	1.0						
DS 8-7	ML 65+84.42 3.4' LT	ADJUST EXISTING FRAME AND GRATE TO PROPOSED FINISHED GRADE AND CLEAN 74 LF OF OUTLET PIPE FROM DS 8-7 TO DS 8-8. REMOVE CONDUIT & PATCH WALL (SEE DETAIL ON DWG. MD-4)	593.97	1.0			1.0	74.0		
DS 8-8	ML 65+89.97 74.2' LT	CLEAN EXISTING DRAINAGE STRUCTURE AND CLEAN 12 LF OF OUTLET PIPE FROM DS 8-8 TO DS 8-9.	-					12.0	1.0	
DS 8-9	ML 65+88.09 85.9' LT	REFER TO DS 8-8.	-							
DS 9-1	ML 68+89.62 1.5' RT	ADJUST EXISTING FRAME AND GRATE TO PROPOSED FINISHED GRADE.	595.47	1.0						
DS 9-2	ML 68+89.94 3.4' LT	ADJUST EXISTING FRAME AND GRATE TO PROPOSED FINISHED GRADE AND CLEAN 73 LF OF OUTLET PIPE FROM DS 9-2 TO DS 9-3. REMOVE CONDUIT & PATCH WALL (SEE DETAIL ON DWG. MD-4)	595.46	1.0			1.0	73.0		
DS 9-3	ML 68+98.78 73.3' LT	CLEAN EXISTING DRAINAGE STRUCTURE AND CLEAN 9 LF OF OUTLET PIPE FROM DS 9-3 TO DS 9-4.	-					9.0	1.0	
DS 9-4	ML 68+98.95 82.0' LT	REFER TO DS 9-3.	-							
DS 9-5	ML 70+70.00 3.4' LT	ADJUST EXISTING FRAME AND GRATE TO PROPOSED FINISHED GRADE AND CLEAN 77 LF OF OUTLET PIPE FROM DS 9-5 TO DS 9-7. REMOVE CONDUIT & PATCH WALL (SEE DETAIL ON DWG. MD-4)	596.41	1.0			1.0	77.0		
DS 9-6	ML 70+70.34 1.6' RT	ADJUST EXISTING FRAME AND GRATE TO PROPOSED FINISHED GRADE.	596.37	1.0						

ITEM	DESCRIPTION	UNITS
604.070501	ALTERING DRAINAGE STRUCTURES, LEACHING BASINS AND MANHOLES - ADJUST RIM	EA
604.070502	ALTERING DRAINAGE STRUCTURES, LEACHING BASINS AND MANHOLES - RECONSTRUCT ROOF SLAB	EA
604.070503	ALTERING DRAINAGE STRUCTURES, LEACHING BASINS AND MANHOLES - REMOVE CONDUIT & PATCH WALL	EA
604.070504	ALTERING DRAINAGE STRUCTURES, LEACHING BASINS AND MANHOLES - ADJUST RIM	EA
621.03	CLEANING CLOSED DRAINAGE SYSTEMS	LF
621.04	CLEANING DRAINAGE STRUCTURES	EA
634.07060001	VIDEO INSPECTION OF PIPELINES	LF

ALTERED ON: _____ AFFIXED ON: 2/5/2026

SIGNATURE: _____ STAMP: _____

IT IS A VIOLATION OF LAW FOR ANY PERSON, UNLESS THEY ARE ACTING UNDER THE DIRECTION OF A LICENSED PROFESSIONAL ENGINEER, ARCHITECT, LANDSCAPE ARCHITECT, OR LAND SURVEYOR, TO ALTER AN ITEM IN ANY WAY. IF AN ITEM BEARING THE STAMP OF A LICENSED PROFESSIONAL IS ALTERED, THE ALTERING ENGINEER, ARCHITECT, LANDSCAPE ARCHITECT, OR LAND SURVEYOR SHALL STAMP THE DOCUMENT AND INCLUDE THE NOTATION "ALTERED BY" FOLLOWED BY THEIR SIGNATURE, THE DATE OF SUCH ALTERATION, AND A SPECIFIC DESCRIPTION OF THE ALTERATION.

REVISIONS

DATE	DESCRIPTION	BY	SYM.

TITLE OF PROJECT: I-190 HIGHWAY REHABILITATION
 LOCATION OF PROJECT: I-190 NIAGARA THRUWAY MP 900.7 TO MP 904.2
 TITLE OF DRAWING: MISCELLANEOUS TABLES

CONTRACT NUMBER: TAN 26-14
 DATE: FEB. 2026
 DRAWING NUMBER: MT-6

DS #	STATION / OFFSET (FT)	DESCRIPTION OF WORK	PROP T.G. ELEV.	ITEM 604.070501 (EA)	ITEM 604.070502 (EA)	ITEM 604.070503 (EA)	ITEM 604.070504 (EA)	ITEM 621.03 (LF)	ITEM 621.04 (EA)	ITEM 634.07060001 (LF)
DS 20-5	ML 150+78.67 48.8' RT	ADJUST EXISTING FRAME AND GRATE TO PROPOSED FINISHED GRADE AND CLEAN AND PERFORM VIDEO INSPECTION OF 26 LF OF OUTLET PIPE FROM DS 20-5 TO DS 20-7.	599.78				1.0	26.0		26.0
DS 20-6	ML 150+81.48 49.0' LT	ADJUST EXISTING FRAME AND GRATE TO PROPOSED FINISHED GRADE AND CLEAN 23 LF OF OUTLET PIPE DS 20-6 TO DS 20-8.	600.06				1.0	23.0		
DS 20-7	ML 151+04.29 49.2' RT	ADJUST EXISTING FRAME AND GRATE TO PROPOSED FINISHED GRADE AND CLEAN AND PERFORM VIDEO INSPECTION OF 63 LF OF OUTLET PIPES FROM DS 20-7 TO DS 20-15.	599.71				1.0	63.0		63.0
DS 20-8	ML 151+04.58 49.5' LT	ADJUST EXISTING FRAME AND GRATE TO PROPOSED FINISHED GRADE AND CLEAN AND PERFORM VIDEO INSPECTION OF 52 LF OF OUTLET PIPES FROM DS 20-8 TO DS 20-9.	600.12				1.0	52.0		52.0
DS 20-9	ML 151+04.59 2.8' LT	ADJUST FRAME AND GRATE TO FINISHED GRADE. INSTALL NEW PARALLEL BAR NO. 11PCB FRAME AND GRATE, ITEM 655.0902. REMOVE CONDUIT & PATCH WALL (SEE DETAIL ON DWG. MD-4)	600.81	1.0		1.0				
DS 20-10	ML 151+04.61 3.1' RT	ADJUST FRAME AND GRATE TO FINISHED GRADE. INSTALL NEW PARALLEL BAR NO. 11PCB FRAME AND GRATE, ITEM 655.0902 AND CLEAN AND PERFORM VIDEO INSPECTION OF 46 LF OF OUTLET PIPE FROM DS 20-10 TO DS 20-7.	600.65	1.0				46.0		46.0
DS 20-11	ML 151+16.66 49.1' LT	ADJUST EXISTING FRAME AND GRATE TO PROPOSED FINISHED GRADE AND CLEAN 13 LF OF OUTLET PIPE FROM DS 20-11 TO DS 20-8.	600.14				1.0	13.0		
DS 20-12	ML 151+17.34 49.1' RT	ADJUST EXISTING FRAME AND GRATE TO PROPOSED FINISHED GRADE AND CLEAN AND PERFORM VIDEO INSPECTION OF 14 LF OF OUTLET PIPE FROM DS 20-12 TO DS 20-7.	599.75				1.0	14.0		14.0
DS 20-13	ML 147+80.47 81.9' RT	CLEAN AND PERFORM VIDEO INSPECTION OF 30 LF OF OUTLET PIPE FROM DS 20-13 TO DS 20-14.	-					30.0		30.0
DS 20-14	ML 147+83.62 112.7' RT	REFER TO DS 20-13.	-							
DS 20-15	ML 150+55.47 89.5' RT	REFER TO DS 20-7.	-							
DS 21-1	ML 154+61.18 48.2' RT	ADJUST EXISTING FRAME AND GRATE TO PROPOSED FINISHED GRADE AND CLEAN 52 LF OF OUTLET PIPE FROM DS 21-1 TO DS 21-11.	605.86				1.0	52.0		
DS 21-2	ML 154+61.14 48.5' LT	ADJUST EXISTING FRAME AND GRATE TO PROPOSED FINISHED GRADE AND CLEAN 51 LF OF OUTLET PIPE FROM DS 21-2 TO DS 21-4.	606.05				1.0	51.0		
DS 21-3	ML 154+73.02 4.0' RT	ADJUST EXISTING FRAME AND GRATE TO PROPOSED FINISHED GRADE AND CLEAN 50 LF OF OUTLET PIPE FROM DS 21-3 TO DS 21-1.	606.64	1.0				50.0		
DS 21-4	ML 154+73.75 2.0' LT	ADJUST EXISTING FRAME AND GRATE TO PROPOSED FINISHED GRADE. REMOVE CONDUIT & PATCH WALL (SEE DETAIL ON DWG. MD-4)	606.62	1.0		1.0				
DS 21-5	ML 156+97.92 51.9' LT	ADJUST EXISTING FRAME AND GRATE TO PROPOSED FINISHED GRADE AND CLEAN 53 LF OF OUTLET PIPE FROM DS 21-5 TO DS 21-7.	611.22				1.0	53.0		
DS 21-6	ML 156+99.53 49.3' RT	ADJUST EXISTING FRAME AND GRATE TO PROPOSED FINISHED GRADE AND CLEAN 66 LF OF OUTLET PIPE DS 21-12.	611.01				1.0	66.0		
DS 21-7	ML 157+06.20 2.4' LT	ADJUST EXISTING FRAME AND GRATE TO PROPOSED FINISHED GRADE. REMOVE CONDUIT & PATCH WALL (SEE DETAIL ON DWG. MD-4)	611.75	1.0		1.0				
DS 21-8	ML 157+06.54 3.5' RT	ADJUST EXISTING FRAME AND GRATE TO PROPOSED FINISHED GRADE AND CLEAN 49 LF OF OUTLET PIPE FROM DS 21-8 TO DS 21-6.	611.77	1.0				49.0		

DS #	STATION / OFFSET (FT)	DESCRIPTION OF WORK	PROP T.G. ELEV.	ITEM 604.070501 (EA)	ITEM 604.070502 (EA)	ITEM 604.070503 (EA)	ITEM 604.070504 (EA)	ITEM 621.03 (LF)	ITEM 621.04 (EA)	ITEM 634.07060001 (LF)
DS 21-9	ML 158+80.54 65.5' LT	CLEAN EXISTING DRAINAGE STRUCTURE AND CLEAN AND PERFORM VIDEO INSPECTION OF 200 LF OF PIPE FROM DS 21-9 TO DS 21-10.	-							200.0
DS 21-10	ML 158+60.87 127.7' RT	CLEAN EXISTING DRAINAGE STRUCTURE AND CLEAN 161 LF OF OUTLET PIPE FROM DS 21-10 TO DS 21-12.	-							161.0
DS 21-11	ML 154+41.36 95.9' RT	CLEAN 50 LF OF OUTLET PIPE. SEE PROPOSED DRAINAGE INSTALLATION TABLE ON DWG. MT-15 FOR PROPOSED WORK.	-							50.0
DS 21-12	ML 157+00.30 114.5' RT	CLEAN EXISTING DRAINAGE STRUCTURE AND CLEAN 259 LF OF OUTLET PIPE FROM DS 21-12 TO DS 21-11.	-							259.0
DS 22-1	ML 164+25.87 51.3' RT	ADJUST EXISTING FRAME AND GRATE TO PROPOSED FINISHED GRADE AND CLEAN 68 LF OF OUTLET PIPE FROM DS 22-1 TO DS 22-4.	611.53				1.0	68.0		
DS 22-2	ML 164+26.69 2.9' LT	ADJUST EXISTING FRAME AND GRATE TO PROPOSED FINISHED GRADE AND CLEAN 54 LF OF OUTLET PIPE FROM DS 22-2 TO DS 22-1. REMOVE CONDUIT & PATCH WALL (SEE DETAIL ON DWG. MD-4)	612.58	1.0		1.0		54.0		
DS 22-3	ML 164+50.36 57.9' LT	ADJUST EXISTING FRAME AND GRATE TO PROPOSED FINISHED GRADE AND CLEAN 59 LF OF OUTLET PIPE FROM DS 22-3 TO DS 22-2.	612.35				1.0	59.0		
DS 22-4	ML 164+28.39 119.4' RT	CLEAN EXISTING DRAINAGE STRUCTURE AND CLEAN 202 LF OF OUTLET PIPE FROM DS 22-4 TO DS 22-8.	-							202.0
DS 22-5	M 3+11.58 35.8' LT	CLEAN EXISTING DRAINAGE STRUCTURE AND CLEAN 106 LF OF OUTLET PIPE FROM DS 22-5 TO DS 22-9.	-							106.0
DS 22-6	ML 166+22.66 2.7' LT	ADJUST EXISTING FRAME AND GRATE TO PROPOSED FINISHED GRADE AND CLEAN 58 LF OF OUTLET PIPE FROM DS 22-6 TO DS 22-7. REMOVE CONDUIT & PATCH WALL (SEE DETAIL ON DWG. MD-4)	609.83	1.0		1.0		58.0		
DS 22-7	ML 166+23.65 56.4' RT	ADJUST EXISTING FRAME AND GRATE TO PROPOSED FINISHED GRADE AND CLEAN 68 LF OF OUTLET PIPE FROM DS 22-5 TO DS 22-8.	607.90				1.0	68.0		
DS 22-8	ML 166+33.64 122.4' RT	CLEAN EXISTING DRAINAGE STRUCTURE AND CLEAN 205 LF OF OUTLET PIPE FROM DS 22-8 TO DS 22-13.	-							205.0
DS 22-9	M 3+23.69 70.3' RT	CLEAN EXISTING DRAINAGE STRUCTURE AND CLEAN 217 LF OF OUTLET PIPE FROM DS 22-9 TO DS 23-1.	-							217.0
DS 22-10	ML 168+13.78 2.6' LT	ADJUST EXISTING FRAME AND GRATE TO PROPOSED FINISHED GRADE. REMOVE CONDUIT & PATCH WALL (SEE DETAIL ON DWG. MD-4)	607.01	1.0		1.0				
DS 22-11	ML 168+14.38 4.0' RT	ADJUST EXISTING FRAME AND GRATE TO PROPOSED FINISHED GRADE AND CLEAN 57 LF OF OUTLET PIPE FROM DS 22-11 TO DS 22-12.	606.92	1.0				57.0		
DS 22-12	ML 168+36.79 53.3' RT	ADJUST EXISTING FRAME AND GRATE TO PROPOSED FINISHED GRADE AND CLEAN 60 LF OF OUTLET PIPE FROM DS 22-12 TO DS 22-13.	605.35				1.0	60.0		
DS 22-13	ML 168+44.65 112.9' RT	CLEAN EXISTING DRAINAGE STRUCTURE AND CLEAN 50 LF OF OUTLET PIPE.	-							50.0
DS 23-1	L 1 5+06.53 69.1' LT	CLEAN EXISTING DRAINAGE STRUCTURE AND CLEAN 116 LF OF OUTLET PIPE FROM DS 23-1 TO DS 23-4.	-							116.0
DS 23-2	L 3+48.55 39.1' RT	CLEAN EXISTING DRAINAGE STRUCTURE AND CLEAN 40 LF OF OUTLET PIPE FROM DS 23-2 TO DS 23-3.	-							40.0
DS 23-3	L 1 3+38.72 2.8' RT	ADJUST EXISTING FRAME AND GRATE TO PROPOSED FINISHED GRADE AND CLEAN 43 LF OF OUTLET PIPE FROM DS 23-3 TO DS 23-4.	-				1.0	43.0		
DS 23-4	L 1 3+25.82 44.5' LT	CLEAN EXISTING DRAINAGE STRUCTURE AND CLEAN 165 LF OF OUTLET PIPE FROM DS 23-4 TO DS 23-5.	-							165.0
DS 23-5	L 1 1+37.71 62.9' LT	CLEAN EXISTING DRAINAGE STRUCTURE AND CLEAN 50 LF OF OUTLET PIPE.	-							50.0
DS 23-6	L 1 1+30.59 52.7' LT	ADJUST EXISTING FRAME AND GRATE TO PROPOSED FINISHED GRADE AND CLEAN 12 LF OF OUTLET PIPE FROM DS 23-6 TO DS 23-5.	-				1.0	12.0		
DS 23-7	L 1 1+30.34 56.8' RT	ADJUST EXISTING FRAME AND GRATE TO PROPOSED FINISHED GRADE AND CLEAN 111 LF OF OUTLET PIPE FROM DS 23-7 TO DS 23-6.	-							111.0

CHECKED BY: J. KLEINMANN

DRAFTED BY: N. HOY

CHECKED BY: J. KLEINMANN

DESIGNED BY: P. THOMPSON

DESIGN SUPERVISOR: D. MARSH

ALTERED ON:	AFFIXED ON: 2/5/2026
SIGNATURE: STAMP:	SIGNATURE: STAMP:

ITEM	DESCRIPTION	UNITS
604.070501	ALTERING DRAINAGE STRUCTURES, LEACHING BASINS AND MANHOLES - ADJUST RIM	EA
604.070502	ALTERING DRAINAGE STRUCTURES, LEACHING BASINS AND MANHOLES - RECONSTRUCT ROOF SLAB	EA
604.070503	ALTERING DRAINAGE STRUCTURES, LEACHING BASINS AND MANHOLES - REMOVE CONDUIT & PATCH WALL	EA
604.070504	ALTERING DRAINAGE STRUCTURES, LEACHING BASINS AND MANHOLES - ADJUST RIM	EA
621.03	CLEANING CLOSED DRAINAGE SYSTEMS	LF
621.04	CLEANING DRAINAGE STRUCTURES	EA
634.07060001	VIDEO INSPECTION OF PIPELINES	LF

IT IS A VIOLATION OF LAW FOR ANY PERSON, UNLESS THEY ARE ACTING UNDER THE DIRECTION OF A LICENSED PROFESSIONAL ENGINEER, ARCHITECT, LANDSCAPE ARCHITECT, OR LAND SURVEYOR, TO ALTER AN ITEM IN ANY WAY. IF AN ITEM BEARING THE STAMP OF A LICENSED PROFESSIONAL IS ALTERED, THE ALTERING ENGINEER, ARCHITECT, LANDSCAPE ARCHITECT, OR LAND SURVEYOR SHALL STAMP THE DOCUMENT AND INCLUDE THE NOTATION "ALTERED BY" FOLLOWED BY THEIR SIGNATURE, THE DATE OF SUCH ALTERATION, AND A SPECIFIC DESCRIPTION OF THE ALTERATION.

REVISIONS			
DATE	DESCRIPTION	BY	SYM.

	TITLE OF PROJECT I-190 HIGHWAY REHABILITATION	CONTRACT NUMBER: TAN 26-14
	LOCATION OF PROJECT I-190 NIAGARA THRUWAY MP 900.7 TO MP 904.2	DATE: FEB. 2026
	TITLE OF DRAWING MISCELLANEOUS TABLES	DRAWING NUMBER: MT-10

THIS SHEET SUPERSEDES SHEET 216
IN ITS ENTIRETY

CHECKED BY: J. KLEINMANN

DRAFTED BY: N. HOY

CHECKED BY: J. KLEINMANN

DESIGNED BY: P. THOMPSON

DESIGN SUPERVISOR: D. MARSH

PROPOSED DRAINAGE INSTALLATION TABLE

DS #	STATION / OFFSET (FT)	DESCRIPTION OF WORK	PROP T.G. ELEV.	INVERTS				ITEM 203.07 (CY)	ITEM 206.0201 (CY)	ITEM 208.5201 (EA)	ITEM 208.5301 (EA)	ITEM 552.17 (SF)	ITEM 603.6002 (LF)	ITEM 603.6003 (LF)	ITEM 603.6005 (LF)	ITEM 603.77 (EA)	ITEM 603.9818 (LF)	ITEM 604.300691 (LF)	ITEM 604.500501 (LF)	ITEM 655.0902 (EA)
				N	S	E	W													
DS 1-1	ML 23+31 2.9' RT	INSTALL PROPOSED 15" RCP OUTLET PIPE AND CONNECT EXISTING RCP WITH CONCRETE COLLARS. SEE MD-6 FOR DETAILS ON PIPE INSTALLATION WORK.	-					66.80	70.80			90.0			2.0					
DS 2-1	ML 28+01 6.0' LT	INSTALL NEW TYPE H DRAINAGE STRUCTURE AND INSTALL 5 LF OF 18" RCP PIPE FROM DS 2-1 TO DS 2-2. SEE MD-12 FOR DETAILS.	602.74					45.30	85.90		620.0				1.0	5.0		10.0	2.0	
DS 2-2	ML 30+79 7.5' LT	INSTALL NEW TYPE H DRAINAGE STRUCTURE AND INSTALL 5 LF OF 18" RCP PIPE FROM DS 2-2 TO DS 2-1, 5 LF FROM DS 2-2 TO EXISTING PIPE SOUTH, & 10 LF FROM DS 2-2 TO EXISTING PIPE NORTH. SEE MD-12 FOR DETAILS.	604.07	592.56	592.56	592.56		78.60	127.80		731.4				3.0	20.0		12.0	2.0	
DS 4-1	A 12+70.85 20.3' RT	CLEAN EXISTING DRAINAGE STRUCTURE AND INSTALL 75 LF OF 18" SICPP OUTLET PIPE FROM DS 4-1 TO DS 4-2. COST TO CONNECT THE NEW PIPE TO STRUCTURE SHALL BE INCLUDED IN THE BID PRICE FOR ITEM 603.9818	593.95	590.72				45.60	52.30							75.0				
DS 4-2	A 13+55.68 23.5' RT	INSTALL NEW TYPE F DRAINAGE STRUCTURE AND INSTALL 108 LF OF 18" SICPP OUTLET PIPE FROM DS 4-2 TO DS 4-6.	594.66		589.97			89.80	105.20		203.80					108.0	6.0			1.0
DS 4-6	C 6+96.40 39.4' RT	INSTALL NEW TYPE F DRAINAGE STRUCTURE. CONNECT EXISTING NE, NW, AND SW PIPES TO NEW STRUCTURE. CLEAN AND PERFORM VIDEO INSPECTION OF 200 LF OF PIPELINE FROM DS 4-6 TO DS 3-6.	593.21	NOTE 1	587.00	588.79		15.00	22.20		256.80						7.0			1.0
DS 7-18	ML 60+15.42 67.96' LT	INSTALL NEW STORMWATER TREATMENT UNIT (SEE DETAILS ON DWG MD-12). CONNECT EXISTING NE, NW, AND SW PIPES TO NEW STRUCTURE. CLEAN 77 LF OF INLET PIPE FROM DS 8-2 TO DS 7-18 AND 140 LFT OF OUTLET PIPE FROM DS 7-18 TO DS 7-10.	589.10		584.20 NOTE 1	584.51 NOTE 1	584.78 NOTE 1	28.60	39.10		1.00	230.10				15.0				
DS 21-11	ML 154+41.36 95.9' RT	INSTALL NEW STORMWATER TREATMENT UNIT (SEE DETAILS ON DWG MD-12). CONNECT EXISTING E, W, AND SW PIPES TO NEW STRUCTURE. CLEAN 50 LF OF OUTLET PIPE FROM DS 21-11 TO EXISTING DS LOCATED IN PEABODY ST.	584.00 NOTE 1		579.72 NOTE 1	579.72 NOTE 1	579.72 NOTE 1	18.90	27.10		1.00	204.50				10.0				
DS 30-11	S 3+49.60 42.6' LT	INSTALL NEW STORMWATER TREATMENT UNIT (SEE DETAILS ON DWG MD-12). CONNECT EXISTING NW AND SW PIPES TO NEW STRUCTURE.	580.14 NOTE 1	575.94 NOTE 1	575.94 NOTE 1			17.10	23.10	1.00		181.70	10.0							
TOTAL								405.7	553.5	1.0	2.0	2428.3	90.0	10.0	15.0	6.0	218.0	13.0	22.0	6.0

PROPOSED DRAINAGE & DRAINAGE REMOVAL ITEMS		
ITEM	DESCRIPTION	UNITS
203.07	SELECT GRANULAR FILL	CY
206.0201	TRENCH AND CULVERT EXCAVATION	CY
208.5201	STORMWATER TREATMENT SYSTEM SWTD - MAXIMUM TREATMENT FLOW RATE OVER 1.0 CFS UP TO 2.0 CFS	EA
208.5301	STORMWATER TREATMENT SYSTEM SWTD - MAXIMUM TREATMENT FLOW RATE OVER 2.0 CFS UP TO 2.8 CFS	EA
552.17	SHIELDS AND SHORING	SF
603.6002	REINFORCED CONCRETE PIPE CLASS III, 15 INCH DIAMETER	LF
603.6003	REINFORCED CONCRETE PIPE CLASS III, 18 INCH DIAMETER	LF
604.6005	REINFORCED CONCRETE PIPE CLASS III, 24 INCH DIAMETER	LF
603.77	CONCRETE COLLARS	EA
603.9818	SMOOTH INTERIOR CORRUGATED POLYETHYLENE CULVERT AND STORMDRAIN 18 INCH DIAMETER	LF
604.300691	RECTANGULAR DRAINAGE STRUCTURE TYPE F FOR PARALLEL BAR #11 PCB FRAME	LF
655.0902	PARALLEL BAR FRAME 11 PCB & PARALLEL BAR GRATE 11 PCB	EA



ITEM 655.0902 FOR DRAINAGE STRUCTURE ADJUSTMENTS			
DS*	STATION	DESCRIPTION OF WORK	ITEM 655.0902 (EA)
DS 3-1	ML 36+42	RESTORE TEMPORARY DRAINAGE ALTERATIONS	1.0
DS 3-2	ML 36+42	RESTORE TEMPORARY DRAINAGE ALTERATIONS	1.0
DS 9-11	ML 73+48	RESTORE TEMPORARY DRAINAGE ALTERATIONS	1.0
DS 9-12	ML 73+48	RESTORE TEMPORARY DRAINAGE ALTERATIONS	1.0
DS 10-1	ML 75+89	RESTORE TEMPORARY DRAINAGE ALTERATIONS	1.0
DS 10-2	ML 75+89	RESTORE TEMPORARY DRAINAGE ALTERATIONS	1.0
DS 10-5	ML 78+51	RESTORE TEMPORARY DRAINAGE ALTERATIONS	1.0
DS 10-6	ML 78+51	RESTORE TEMPORARY DRAINAGE ALTERATIONS	1.0
DS 20-3	ML 147+91	RESTORE TEMPORARY DRAINAGE ALTERATIONS	1.0
DS 20-4	ML 147+91	RESTORE TEMPORARY DRAINAGE ALTERATIONS	1.0
DS 20-9	ML 151+05	RESTORE TEMPORARY DRAINAGE ALTERATIONS	1.0
DS 20-10	ML 151+05	RESTORE TEMPORARY DRAINAGE ALTERATIONS	1.0
DS 27-2	ML 190+12	RESTORE TEMPORARY DRAINAGE ALTERATIONS	1.0
DS 27-3	ML 190+12	RESTORE TEMPORARY DRAINAGE ALTERATIONS	1.0
DS 27-5	ML 193+62	RESTORE TEMPORARY DRAINAGE ALTERATIONS	1.0
DS 27-7	ML 193+62	RESTORE TEMPORARY DRAINAGE ALTERATIONS	1.0
DS 32-9	ML 224+11	RESTORE TEMPORARY DRAINAGE ALTERATIONS	1.0
TOTAL			17.0

- NOTES:
- CONTRACTOR SHALL FIELD VERIFY THE EXISTING PIPE SIZES & INVERTS OF DS 4-6, DS 7-18, DS 21-11, & DS 30-11.
 - COST TO CONNECT ALL EXISTING DRAINAGE PIPES TO THE PROPOSED STORMWATER TREATMENT UNITS, INCLUDING BUT NOT LIMITED TO ADDITIONAL PIPE BEYOND THE QUANTITY SHOWN IN THE TABLE AND CONCRETE COLLARS, SHALL BE INCLUDED IN THE PRICE BID FOR ITEMS 208.5201 & 208.5301.

ALTERED ON:	AFFIXED ON: 2/5/2026
SIGNATURE: STAMP:	SIGNATURE: STAMP: 

IT IS A VIOLATION OF LAW FOR ANY PERSON, UNLESS THEY ARE ACTING UNDER THE DIRECTION OF A LICENSED PROFESSIONAL ENGINEER, ARCHITECT, LANDSCAPE ARCHITECT, OR LAND SURVEYOR, TO ALTER AN ITEM IN ANY WAY. IF AN ITEM BEARING THE STAMP OF A LICENSED PROFESSIONAL IS ALTERED, THE ALTERING ENGINEER, ARCHITECT, LANDSCAPE ARCHITECT, OR LAND SURVEYOR SHALL STAMP THE DOCUMENT AND INCLUDE THE NOTATION "ALTERED BY" FOLLOWED BY THEIR SIGNATURE, THE DATE OF SUCH ALTERATION, AND A SPECIFIC DESCRIPTION OF THE ALTERATION.

REVISIONS			
DATE	DESCRIPTION	BY	SYM.

 	TITLE OF PROJECT I-190 HIGHWAY REHABILITATION	CONTRACT NUMBER: TAN 26-14
	LOCATION OF PROJECT I-190 NIAGARA THRUWAY MP 900.7 TO MP 904.2	DATE: FEB. 2026
TITLE OF DRAWING MISCELLANEOUS TABLES	DRAWING NUMBER: MT-15	

THIS SHEET SUPERSEDES SHEET 252
IN ITS ENTIRETY

FULL DEPTH REPAIR

FULL DEPTH REPAIR																						
LOCATION						REPAIR DIMENSIONS															REMARKS	
MILE MARKER	START SLAB	START STATION	END SLAB	END STATION	LANE	LENGTH (FT)	WIDTH (FT)	AREA (SF)	ITEM 304.00010018 (SF)	ITEM 404.1959 (TON)	ITEM 404.3789 (TON)	ITEM 407.01040009 (GAL)	ITEM 502.90010018 (LF)	ITEM 502.9310 (LF)	ITEM 510.00120018 (CY)	ITEM 510.20000018 (SY)	ITEM 510.81000018 (EA)	ITEM 510.81100018 (EA)	ITEM 510.91000018 (LF) (HINGE)	ITEM 510.91000018 (LF)		ITEM 510.91100018 (LF)
901.24	S6	SB 67+20	S6	SB 67+30	A	10.0	12.0	120.0	120.0					10.0	3.7	13.3	16				10.0	
901.24	S6	SB 67+20	S6	SB 67+31	R	10.0	12.0	120.0	120.0						3.7	13.3	16	3				
901.24	S6	SB 67+21	S6	SB 67+31	C	10.0	12.0	120.0	120.0					10.0	3.7	13.3	16				10.0	
901.24	S6	SB 67+21	S6	SB 67+31	L	10.0	12.0	120.0	120.0						3.7	13.3	16					
901.24	S7	SB 67+44	S7	SB 67+66	R	22.0	12.0	264.0	264.0				12.0		8.1	29.3	16			12.0		
901.25	S7	SB 67+56	S8	SB 67+79	A	23.0	12.0	276.0	276.0				12.0	10.0	8.5	30.7	16			12.0	10.0	
901.25	S8	SB 67+89	S8	SB 68+03	C	14.0	12.0	168.0	168.0						5.2	18.7	16					
901.25	S8	SB 67+95	S8	SB 68+03	A	8.0	12.0	96.0	96.0					8.0	3.0	10.7	16				8.0	
901.25	S8	SB 67+95	S8	SB 68+03	R	8.0	12.0	96.0	96.0						3.0	10.7	16					
901.26	S9	SB 68+33	S10	SB 68+61	C	28.0	12.0	336.0	336.0				12.0		10.4	37.3	16	9		12.0		
901.26	S9	SB 68+33	S10	SB 68+61	L	28.0	12.0	336.0	336.0				12.0	28.0	10.4	37.3	16			12.0	28.0	
901.26	S9	SB 68+47	S10	SB 68+61	R	14.0	12.0	168.0	168.0						5.2	18.7	16					
901.27	S10	SB 68+75	S11	SB 69+02	A	27.0	12.0	324.0	324.0				12.0	13.0	10.0	36.0	16			12.0	13.0	
901.27	S10	SB 68+75	S10	SB 68+88	R	13.0	12.0	156.0	156.0						4.8	17.3	16	4				
901.27	S10	SB 68+75	S10	SB 68+88	C	13.0	12.0	156.0	156.0					13.0	4.8	17.3	16					13.0
901.27	S10	SB 68+76	S11	SB 69+02	L	27.0	12.0	324.0	324.0				12.0		10.0	36.0	16			12.0		
901.28	S11	SB 69+16	S11	SB 69+24	R	8.0	12.0	96.0	96.0						3.0	10.7	16	2				
901.28	S11	SB 69+16	S11	SB 69+24	C	8.0	12.0	96.0	96.0						3.0	10.7	16					
901.28	S11	SB 69+16	S11	SB 69+29	L	13.0	12.0	156.0	156.0						4.8	17.3	16					
901.29	S12	SB 69+61	S12	SB 69+70	A	8.0	12.0	96.0	96.0					8.0	3.0	10.7	16				8.0	
901.29	S12	SB 69+62	S12	SB 69+70	R	8.0	12.0	96.0	96.0						3.0	10.7	16	2				
901.29	S12	SB 69+62	S12	SB 69+70	C	8.0	12.0	96.0	96.0						3.0	10.7	16					
901.29	S13	SB 70+02	S13	SB 70+10	R	8.0	12.0	96.0	96.0						3.0	10.7	16	2				
901.29	S13	SB 70+02	S13	SB 70+10	C	8.0	12.0	96.0	96.0						3.0	10.7	16					
901.30	S1	SB 70+38	S1	SB 70+46	R	8.0	12.0	96.0	96.0					8.0	3.0	10.7	16				8.0	
901.30	S1	SB 70+38	S1	SB 70+46	C	8.0	12.0	96.0	96.0						3.0	10.7	16	2				
901.30	S1	SB 70+38	S1	SB 70+46	L	8.0	12.0	96.0	96.0						3.0	10.7	16					
901.31	S2	SB 70+78	S2	SB 70+87	R	8.0	12.0	96.0	96.0					8.0	3.0	10.7	16				8.0	
901.31	S2	SB 70+78	S2	SB 70+86	C	8.0	12.0	96.0	96.0						3.0	10.7	16					
901.32	S3	SB 71+21	S4	SB 71+65	R	44.0	12.0	528.0	528.0				24.0	44.0	16.3	58.7	16			24.0	44.0	
901.32	S3	SB 71+21	S4	SB 71+65	C	44.0	12.0	528.0	528.0				24.0		16.3	58.7	16			24.0		
901.33	S4	SB 71+57	S4	SB 71+65	L	8.0	12.0	96.0	96.0						3.0	10.7	16					
901.33	S4	SB 71+79	S5	SB 71+87	C	8.0	12.0	96.0	96.0						3.0	10.7	16					
901.33	S5	SB 72+01	S5	SB 72+09	R	8.0	12.0	96.0	96.0					8.0	3.0	10.7	16				8.0	
901.33	S5	SB 72+02	S5	SB 72+10	C	8.0	12.0	96.0	96.0						3.0	10.7	16					
901.34	S6	SB 72+39	S6	SB 72+47	R	8.0	12.0	96.0	96.0					8.0	3.0	10.7	16				8.0	
901.34	S6	SB 72+39	S6	SB 72+47	C	8.0	12.0	96.0	96.0						3.0	10.7	16					
901.35	S6	SB 72+59	S7	SB 72+67	R	8.0	12.0	96.0	96.0						3.0	10.7	16					
901.35	S7	SB 72+89	S7	SB 72+97	R	8.0	12.0	96.0	96.0					8.0	3.0	10.7	16				8.0	
901.35	S7	SB 72+89	S7	SB 72+97	C	8.0	12.0	96.0	96.0						3.0	10.7	16					
901.36	S8	SB 73+15	S9	SB 73+67	R	52.0	12.0	624.0	624.0				36.0	23.0	19.3	69.3	16			36.0	23.0	
901.36	S8	SB 73+15	S8	SB 73+39	C	23.0	12.0	276.0	276.0	6.7	10.3	1.1				30.7						
901.36	S9	SB 73+59	S9	SB 73+67	C	8.0	12.0	96.0	96.0	2.3	3.6	0.4				10.7						

SEE PLAN ON DWG. CPR-5

CHECKED BY: J. KLEINMANN

DRAFTED BY: N. HOY

CHECKED BY: J. KLEINMANN

DESIGNED BY: P. AMICONE



DESIGN SUPERVISOR: D. MARSH

ALTERED ON:	AFFIXED ON: 2/5/2026
SIGNATURE: STAMP:	SIGNATURE: STAMP: 

ITEM	DESCRIPTION	UNITS	ITEM	DESCRIPTION	UNITS
304.00010018	FINE GRADING OF EXISTING SUBBASE	SF	510.00120018	PORTLAND CEMENT CONCRETE (PCC) FOR FULL-DEPTH PAVEMENT REPAIRS -UNREINFORCED, PEM, FRICTION TYPE 2	CY
404.1959	19 F9 BINDER COURSE WMA, 50 SERIES COMPACTION	TON	510.20000018	PORTLAND CEMENT CONCRETE (PCC) PAVEMENT LIFT OUT	SY
404.3789	37.5 F9 BASE COURSE WMA, 80 SERIES COMPACTION	TON	510.81000018	DRILL AND ANCHOR DOWELS FOR PCC PAVEMENT REPAIRS	EA
407.01040009	NON-TRACKING TACK COAT	GAL	510.81000018	DRILL AND ANCHOR TIES FOR PCC PAVEMENT REPAIRS	EA
502.90010018	CLEAN AND FILL CRACKS AND JOINTS IN PORTLAND CEMENT CONCRETE(PCC) PAVEMENT, ASTM D 6690 TYPE IV	LF	510.91000018	TRANSVERSE JOINTS FOR PCC PAVEMENT REPAIRS	LF
502.9310	SEALING LONGITUDINAL JOINTS - HIGHWAY JOINT SEALER	LF	510.91100018	LONGITUDINAL JOINTS FOR PCC PAVEMENT REPAIRS	LF

IT IS A VIOLATION OF LAW FOR ANY PERSON, UNLESS THEY ARE ACTING UNDER THE DIRECTION OF A LICENSED PROFESSIONAL ENGINEER, ARCHITECT, LANDSCAPE ARCHITECT, OR LAND SURVEYOR, TO ALTER AN ITEM IN ANY WAY. IF AN ITEM BEARING THE STAMP OF A LICENSED PROFESSIONAL IS ALTERED, THE ALTERING ENGINEER, ARCHITECT, LANDSCAPE ARCHITECT, OR LAND SURVEYOR SHALL STAMP THE DOCUMENT AND INCLUDE THE NOTATION "ALTERED BY" FOLLOWED BY THEIR SIGNATURE, THE DATE OF SUCH ALTERATION, AND A SPECIFIC DESCRIPTION OF THE ALTERATION.

REVISIONS			
DATE	DESCRIPTION	BY	SYM.

	TITLE OF PROJECT I-190 HIGHWAY REHABILITATION	CONTRACT NUMBER: TAN 26-14
	LOCATION OF PROJECT I-190 NIAGARA THRUWAY MP 900.7 TO MP 904.2	DATE: FEB. 2026
	TITLE OF DRAWING CONCRETE PAVEMENT REPAIR TABLE	DRAWING NUMBER: CPRT-5

THIS SHEET SUPERSEDES SHEET 253
IN ITS ENTIRETY

FULL DEPTH REPAIR																						
LOCATION						REPAIR DIMENSIONS																REMARKS
MILE MARKER	START SLAB	START STATION	END SLAB	END STATION	LANE	LENGTH (FT)	WIDTH (FT)	AREA (SF)	ITEM 304.00010018 (SF)	ITEM 404.1959 (TON)	ITEM 404.3789 (TON)	ITEM 407.01040009 (GAL)	ITEM 502.90010018 (LF)	ITEM 502.9310 (LF)	ITEM 510.00120018 (CY)	ITEM 510.20000018 (SY)	ITEM 510.81000018 (EA)	ITEM 510.81100018 (EA)	ITEM 510.91000018 (LF) (HINGE)	ITEM 510.91000018 (LF)	ITEM 510.91100018 (LF)	
901.37	S9	SB 73+81	S10	SB 73+89	C	8.0	12.0	96.0	96.0	2.3	3.6	0.4				10.7						
901.37	S9	SB 73+81	S10	SB 73+89	L	8.0	12.0	96.0	96.0						3.0	10.7	16					
901.22	N3	NB 67+59	N4	NB 67+67	C	8.0	12.0	96.0	96.0					8.0	3.0	10.7	16				8.0	
901.22	N3	NB 67+59	N4	NB 67+67	R	8.0	12.0	96.0	96.0						3.0	10.7	16					
901.23	N4	NB 67+99	N5	NB 68+07	R	8.0	12.0	96.0	96.0						3.0	10.7	16					
901.24	N5	NB 68+39	N6	NB 68+48	C	10.0	12.0	120.0	120.0						3.7	13.3	16					
901.24	N5	NB 68+39	N6	NB 68+48	R	10.0	12.0	120.0	120.0					8.0	3.7	13.3	16				8.0	
901.25	N7	NB 69+03	N7	NB 69+11	C	8.0	12.0	96.0	96.0						3.0	10.7	16					
901.25	N7	NB 69+03	N7	NB 69+11	R	8.0	12.0	96.0	96.0					8.0	3.0	10.7	16				8.0	
901.26	N8	NB 69+60	N9	NB 69+68	C	8.0	12.0	96.0	96.0						3.0	10.7	16					
901.28	N12	NB 70+85	N14	NB 71+89	A	104.0	6.0	624.0	624.0				36.0	30.0	19.3	69.3	4		36.0	30.0		
901.29	N12	NB 71+00	N13	NB 71+30	R	30.0	12.0	360.0	360.0				12.0		11.1	40.0	16	5		12.0		
901.29	N12	NB 71+16	N13	NB 71+30	C	15.0	12.0	180.0	180.0						5.6	20.0	16					
901.30	N13	NB 71+62	N14	NB 71+70	C	8.0	12.0	96.0	96.0						3.0	10.7	16					
901.30	N14	NB 72+00	N1	NB 72+10	R	10.0	12.0	120.0	120.0						3.7	13.3	16					
901.31	N2	NB 72+58	N3	NB 73+09	A	52.0	12.0	624.0	624.0				36.0	26.0	19.3	69.3	16		36.0	26.0		
901.31	N2	NB 72+71	N3	NB 72+96	R	26.0	12.0	312.0	312.0				12.0		9.6	34.7	16		12.0			
901.32	N4	NB 73+37	N4	NB 73+57	R	20.0	12.0	240.0	240.0				12.0		7.4	26.7	16		12.0			
901.32	N4	SB 73+37	N4	SB 73+57	A	20.0	12.0	240.0	240.0				12.0	20.0	7.4	26.7	16		12.0		20.0	

SEE PLAN ON DWG. CPR-5

CHECKED BY: J. KLEINMANN

DRAFTED BY: N. HOY

CHECKED BY: J. KLEINMANN

DESIGNED BY: P. AMICONE

DESIGN SUPERVISOR: D. MARSH



ALTERED ON:	AFFIXED ON: 2/5/2026
SIGNATURE: STAMP:	SIGNATURE: STAMP:



ITEM	DESCRIPTION	UNITS	ITEM	DESCRIPTION	UNITS
304.00010018	FINE GRADING OF EXISTING SUBBASE	SF	510.00120018	PORTLAND CEMENT CONCRETE (PCC) FOR FULL-DEPTH PAVEMENT REPAIRS -UNREINFORCED, PEM, FRICTION TYPE 2	CY
404.1959	19 F9 BINDER COURSE WMA, 50 SERIES COMPACTION	TON	510.20000018	PORTLAND CEMENT CONCRETE (PCC) PAVEMENT LIFT OUT	SY
404.3789	37.5 F9 BASE COURSE WMA, 80 SERIES COMPACTION	TON	510.81000018	DRILL AND ANCHOR DOWELS FOR PCC PAVEMENT REPAIRS	EA
407.01040009	NON-TRACKING TACK COAT	GAL	510.81100018	DRILL AND ANCHOR TIES FOR PCC PAVEMENT REPAIRS	EA
502.90010018	CLEAN AND FILL CRACKS AND JOINTS IN PORTLAND CEMENT CONCRETE(PCC) PAVEMENT, ASTM D 6690 TYPE IV	LF	510.91000018	TRANSVERSE JOINTS FOR PCC PAVEMENT REPAIRS	LF
502.9310	SEALING LONGITUDINAL JOINTS - HIGHWAY JOINT SEALER	LF	510.91100018	LONGITUDINAL JOINTS FOR PCC PAVEMENT REPAIRS	LF

IT IS A VIOLATION OF LAW FOR ANY PERSON, UNLESS THEY ARE ACTING UNDER THE DIRECTION OF A LICENSED PROFESSIONAL ENGINEER, ARCHITECT, LANDSCAPE ARCHITECT, OR LAND SURVEYOR, TO ALTER AN ITEM IN ANY WAY. IF AN ITEM BEARING THE STAMP OF A LICENSED PROFESSIONAL IS ALTERED, THE ALTERING ENGINEER, ARCHITECT, LANDSCAPE ARCHITECT, OR LAND SURVEYOR SHALL STAMP THE DOCUMENT AND INCLUDE THE NOTATION "ALTERED BY" FOLLOWED BY THEIR SIGNATURE, THE DATE OF SUCH ALTERATION, AND A SPECIFIC DESCRIPTION OF THE ALTERATION.

REVISIONS			
DATE	DESCRIPTION	BY	SYMBOL

	TITLE OF PROJECT I-190 HIGHWAY REHABILITATION	CONTRACT NUMBER: TAN 26-14
	LOCATION OF PROJECT I-190 NIAGARA THRUWAY MP 900.7 TO MP 904.2	DATE: FEB. 2026
	TITLE OF DRAWING CONCRETE PAVEMENT REPAIR TABLE	DRAWING NUMBER: CPRT-6

THIS SHEET SUPERSEDES SHEET 254
IN ITS ENTIRETY

FULL DEPTH REPAIR

FULL DEPTH REPAIR																						
LOCATION						REPAIR DIMENSIONS															REMARKS	
MILE MARKER	START SLAB	START STATION	END SLAB	END STATION	LANE	LENGTH (FT)	WIDTH (FT)	AREA (SF)	ITEM 304.00010018 (SF)	ITEM 404.1959 (TON)	ITEM 404.3789 (TON)	ITEM 407.01040009 (GAL)	ITEM 502.90010018 (LF)	ITEM 502.9310 (LF)	ITEM 510.00120018 (CY)	ITEM 510.20000018 (SY)	ITEM 510.81000018 (EA)	ITEM 510.81100018 (EA)	ITEM 510.91000018 (LF) (HINGE)	ITEM 510.91000018 (LF)		ITEM 510.91100018 (LF)
901.38	S11	SB 74+62	S12	SB 74+70	R	8.0	12.0	96.0	96.0					8.0	3.0	10.7	16				8.0	
901.38	S11	SB 74+62	S12	SB 74+70	C	8.0	12.0	96.0	96.0	2.3	3.6	0.4				10.7						
901.38	S11	SB 74+62	S12	SB 74+70	L	8.0	12.0	96.0	96.0						3.0	10.7	16					
901.39	S12	SB 74+84	S13	SB 75+07	R	23.0	12.0	276.0	276.0					15.0	8.5	30.7	16					15.0
901.39	S12	SB 74+84	S12	SB 74+99	C	15.0	12.0	180.0	180.0	4.4	6.7	0.7				20.0						
901.39	S12	SB 74+84	S12	SB 74+99	L	15.0	12.0	180.0	180.0						5.6	20.0	16					
901.39	S13	SB 75+19	S13	SB 75+27	R	8.0	12.0	96.0	96.0					8.0	3.0	10.7	16					8.0
901.39	S13	SB 75+19	S13	SB 75+27	C	8.0	12.0	96.0	96.0	2.3	3.6	0.4				10.7						
901.39	S13	SB 75+42	S14	SB 75+72	R	30.0	12.0	360.0	360.0				12.0	30.0	11.1	40.0	16			12.0		30.0
901.39	S13	SB 75+42	S14	SB 75+72	C	30.0	12.0	360.0	360.0	8.8	13.5	1.4				40.0						
901.40	S14	SB 75+57	S14	SB 75+72	L	15.0	12.0	180.0	180.0						5.6	20.0	16					
901.41	S1	SB 76+16	S3	SB 76+92	R	76.0	12.0	912.0	912.0				60.0	50.0	28.1	101.3	16			60.0		50.0
901.41	S2	SB 76+35	S3	SB 76+92	C	58.0	12.0	696.0	696.0	17.0	26.1	2.7				77.3						
901.42	S3	SB 76+81	S3	SB 76+92	L	11.0	12.0	132.0	132.0						4.1	14.7	16	3				
901.43	S4	SB 77+26	S5	SB 77+46	R	20.0	12.0	240.0	240.0				12.0	10.0	7.4	26.7	16			12.0		10.0
901.43	S4	SB 77+26	S4	SB 77+36	C	10.0	12.0	120.0	120.0	2.9	4.5	0.5				13.3						
901.44	S5	SB 77+61	S5	SB 77+73	R	12.0	12.0	144.0	144.0					12.0	4.4	16.0	16					12.0
901.44	S5	SB 77+61	S5	SB 77+73	C	12.0	12.0	144.0	144.0	3.5	5.4	0.6				16.0						
901.44	S6	SB 77+98	S7	SB 78+47	R	49.0	12.0	588.0	588.0				36.0	49.0	18.1	65.3	16			36.0		49.0
901.44	S6	SB 77+98	S7	SB 78+47	C	49.0	12.0	588.0	588.0	14.3	22.0	2.3				65.3						
901.45	S7	SB 78+37	S7	SB 78+47	A	10.0	12.0	120.0	120.0						3.7	13.3	16	3				
901.46	S8	SB 78+79	S8	SB 78+87	R	8.0	12.0	96.0	96.0					8.0	3.0	10.7	16					8.0
901.46	S8	SB 78+79	S8	SB 78+87	C	8.0	12.0	96.0	96.0	2.3	3.6	0.4				10.7						
901.47	S9	SB 79+37	S10	SB 79+52	A	15.0	12.0	180.0	180.0					15.0	5.6	20.0	16					15.0
901.47	S9	SB 79+36	S10	SB 79+52	R	15.0	12.0	180.0	180.0						5.6	20.0	16	5				
901.47	S9	SB 79+37	S10	SB 79+52	C	15.0	12.0	180.0	180.0	4.4	6.7	0.7				20.0						
901.47	S10	SB 79+52	S10	SB 79+61	L	9.0	12.0	108.0	108.0						3.3	12.0	16					
901.48	S11	SB 80+00	S11	SB 80+13	R	13.0	12.0	156.0	156.0						4.8	17.3	16	4				
901.48	S11	SB 80+00	S11	SB 80+13	C	13.0	12.0	156.0	156.0						4.8	17.3	16					
901.49	S12	SB 80+40	S12	SB 80+52	R	12.0	12.0	144.0	144.0						4.4	16.0	16	4				
901.49	S12	SB 80+40	S1	SB 81+36	C	96.0	12.0	1152.0	1152.0				72.0		35.6	128.0	16			72.0		
901.49	S12	SB 80+63	S13	SB 80+74	L	11.0	12.0	132.0	132.0						4.1	14.7	16					
901.50	S13	SB 80+74	S13	SB 80+86	A	12.0	12.0	144.0	144.0					12.0	4.4	16.0	16					12.0
901.50	S13	SB 80+86	S13	SB 80+99	R	13.0	12.0	156.0	156.0						4.8	17.3	16	4				
901.35	N7	NB 74+55	N7	NB 74+63	A	8.0	12.0	96.0	96.0						3.0	10.7	16					
901.35	N7	NB 74+80	N8	NB 74+88	C	8.0	12.0	96.0	96.0	2.3	3.6	0.4				10.7						
901.37	N10	NB 75+78	N10	NB 75+86	A	8.0	12.0	96.0	96.0						3.0	10.7	16					
901.38	N11	NB 76+46	N12	NB 76+66	A	21.0	12.0	252.0	252.0				12.0		7.8	28.0	16		12.0			
901.39	N13	NB 76+97	N13	NB 77+05	L	8.0	12.0	96.0	96.0						3.0	10.7	16					
901.40	N14	NB 77+53	N14	NB 77+63	A	10.0	12.0	120.0	120.0						3.7	13.3	16					
901.40	N1	NB 77+79	N1	NB 77+94	L	15.0	12.0	180.0	180.0						5.6	20.0	16					
901.40	N1	NB 77+82	N1	NB 77+92	A	10.0	12.0	120.0	120.0						3.7	13.3	16					
901.41	N1	NB 78+04	N2	NB 78+30	R	26.0	12.0	312.0	312.0				12.0		9.6	34.7	16		12.0			
901.44	N6	NB 80+01	N7	NB 80+09	R	8.0	12.0	96.0	96.0						3.0	10.7	16					
901.45	N7	NB 80+41	N8	NB 80+49	R	8.0	12.0	96.0	96.0						3.0	10.7	16					

SEE PLAN ON DWG. CPR-6

CHECKED BY: J. KLEINMANN

DRAFTED BY: N. HOY

CHECKED BY: J. KLEINMANN

DESIGNED BY: P. AMICONE



DESIGN SUPERVISOR: D. MARSH

ALTERED ON:	AFFIXED ON: 2/5/2026
SIGNATURE: STAMP:	SIGNATURE: STAMP: 

ITEM	DESCRIPTION	UNITS	ITEM	DESCRIPTION	UNITS
304.00010018	FINE GRADING OF EXISTING SUBBASE	SF	510.00120018	PORTLAND CEMENT CONCRETE (PCC) FOR FULL-DEPTH PAVEMENT REPAIRS -UNREINFORCED, PEM, FRICTION TYPE 2	CY
404.1959	19 F9 BINDER COURSE WMA, 50 SERIES COMPACTION	TON	510.20000018	PORTLAND CEMENT CONCRETE (PCC) PAVEMENT LIFT OUT	SY
404.3789	37.5 F9 BASE COURSE WMA, 80 SERIES COMPACTION	TON	510.81000018	DRILL AND ANCHOR DOWELS FOR PCC PAVEMENT REPAIRS	EA
407.01040009	NON-TRACKING TACK COAT	GAL	510.81100018	DRILL AND ANCHOR TIES FOR PCC PAVEMENT REPAIRS	EA
502.90010018	CLEAN AND FILL CRACKS AND JOINTS IN PORTLAND CEMENT CONCRETE(PCC) PAVEMENT, ASTM D 6690 TYPE IV	LF	510.91000018	TRANSVERSE JOINTS FOR PCC PAVEMENT REPAIRS	LF
502.9310	SEALING LONGITUDINAL JOINTS - HIGHWAY JOINT SEALER	LF	510.91100018	LONGITUDINAL JOINTS FOR PCC PAVEMENT REPAIRS	LF

IT IS A VIOLATION OF LAW FOR ANY PERSON, UNLESS THEY ARE ACTING UNDER THE DIRECTION OF A LICENSED PROFESSIONAL ENGINEER, ARCHITECT, LANDSCAPE ARCHITECT, OR LAND SURVEYOR, TO ALTER AN ITEM IN ANY WAY. IF AN ITEM BEARING THE STAMP OF A LICENSED PROFESSIONAL IS ALTERED, THE ALTERING ENGINEER, ARCHITECT, LANDSCAPE ARCHITECT, OR LAND SURVEYOR SHALL STAMP THE DOCUMENT AND INCLUDE THE NOTATION "ALTERED BY" FOLLOWED BY THEIR SIGNATURE, THE DATE OF SUCH ALTERATION, AND A SPECIFIC DESCRIPTION OF THE ALTERATION.

REVISIONS			
DATE	DESCRIPTION	BY	SYM.

	TITLE OF PROJECT I-190 HIGHWAY REHABILITATION	CONTRACT NUMBER: TAN 26-14
	LOCATION OF PROJECT I-190 NIAGARA THRUWAY MP 900.7 TO MP 904.2	DATE: FEB. 2026
	TITLE OF DRAWING CONCRETE PAVEMENT REPAIR TABLE	DRAWING NUMBER: CPRT-7

THIS SHEET SUPERSEDES SHEET 262
IN ITS ENTIRETY

ITEM	DESCRIPTION	UNITS
304.00010018	FINE GRADING OF EXISTING SUBBASE	SF
404.1959	19 F9 BINDER COURSE WMA, 50 SERIES COMPACTION	TON
404.3789	37.5 F9 BASE COURSE WMA, 80 SERIES COMPACTION	TON
407.01040009	NON-TRACKING TACK COAT	GAL
502.90010018	CLEAN AND FILL CRACKS AND JOINTS IN PORTLAND CEMENT CONCRETE(PCC) PAVEMENT, ASTM D 6690 TYPE IV	LF
502.9310	SEALING LONGITUDINAL JOINTS - HIGHWAY JOINT SEALER	LF
510.00120018	PORTLAND CEMENT CONCRETE (PCC) FOR FULL-DEPTH PAVEMENT REPAIRS -UNREINFORCED, PEM, FRICTION TYPE 2	CY
510.20000018	PORTLAND CEMENT CONCRETE (PCC) PAVEMENT LIFT OUT	SY
510.81000018	DRILL AND ANCHOR DOWELS FOR PCC PAVEMENT REPAIRS	EA
510.81100018	DRILL AND ANCHOR TIES FOR PCC PAVEMENT REPAIRS	EA
510.91000018	TRANSVERSE JOINTS FOR PCC PAVEMENT REPAIRS	LF
510.91100018	LONGITUDINAL JOINTS FOR PCC PAVEMENT REPAIRS	LF

FULL DEPTH REPAIR																						
LOCATION						REPAIR DIMENSIONS			ITEMS													REMARKS
MILE MARKER	START SLAB	START STATION	END SLAB	END STATION	LANE	LENGTH (FT)	WIDTH (FT)	AREA (SF)	ITEM 304.00010018 (SF)	ITEM 404.1959 (TON)	ITEM 404.3789 (TON)	ITEM 407.01040009 (GAL)	ITEM 502.90010018 (LF)	ITEM 502.9310 (LF)	ITEM 510.00120018 (CY)	ITEM 510.20000018 (SY)	ITEM 510.81000018 (EA)	ITEM 510.81100018 (EA)	ITEM 510.91000018 (LF) (HINGE)	ITEM 510.91000018 (LF)	ITEM 510.91100018 (LF)	
902.71	S1	SB 146+31	S2	SB 146+39	R	8.0	12.0	96.0	96.0						3.0	10.7	16					
902.71	S2	SB 146+53	S2	SB 146+61	L	8.0	12.0	96.0	96.0						3.0	10.7	16					
902.72	S2	SB 146+71	S3	SB 146+79	C	8.0	12.0	96.0	96.0						3.0	10.7	16					
902.72	S3	SB 146+92	S3	SB 147+02	R	10.0	12.0	120.0	120.0					10.0	3.7	13.3	16					10.0
902.72	S3	SB 146+92	S3	SB 147+02	C	10.0	12.0	120.0	120.0						3.7	13.3	16	3				
902.72	S3	SB 146+92	S3	SB 147+02	L	10.0	12.0	120.0	120.0						3.7	13.3	16					
902.72	S3	SB 147+10	S4	SB 147+18	R	8.0	12.0	96.0	96.0						3.0	10.7	16					
902.72	S3	SB 147+10	S4	SB 147+18	L	8.0	12.0	96.0	96.0						3.0	10.7	16					
902.73	S4	SB 147+51	S5	SB 147+61	C	10.0	12.0	120.0	120.0						3.7	13.3	16					
902.73	S4	SB 147+54	S5	SB 147+61	R	8.0	12.0	96.0	96.0						3.0	10.7	16					
902.74	S5	SB 147+88	S6	SB 147+96	R	8.0	12.0	96.0	96.0						3.0	10.7	16					
902.74	S6	SB 148+03	S6	SB 148+15	C	12.0	12.0	144.0	144.0						4.4	16.0	16					
902.74	S6	SB 148+23	S7	SB 148+43	R	20.0	12.0	240.0	240.0				12.0		7.4	26.7	16		12			
902.75	S7	SB 148+65	S8	SB 148+95	R	30.0	12.0	360.0	360.0				12.0		11.1	40.0	16		12			
902.75	S7	SB 148+68	S8	SB 148+76	C	8.0	12.0	96.0	96.0	2.3	3.6	0.4										
902.76	S8	SB 148+95	S8	SB 149+03	C	8.0	12.0	96.0	96.0	2.3	3.6	0.4										
902.76	S8	SB 149+12	S9	SB 149+36	R	24.0	12.0	288.0	288.0				12.0	24.0	8.9	32.0	16		12			24.0
902.76	S8	SB 149+12	S9	SB 149+36	C	24.0	12.0	288.0	288.0	7.0	10.8	1.1										
902.76	S8	SB 149+12	S9	SB 149+44	L	8.0	12.0	96.0	96.0						3.0	10.7	16					
902.77	S9	SB 149+44	S10	SB 149+56	L	12.0	12.0	144.0	144.0						4.4	16.0	16					
902.78	S10	SB 149+91	S11	SB 149+99	R	8.0	12.0	96.0	96.0					8.0	3.0	10.7	16					8.0
902.78	S10	SB 149+91	S11	SB 149+99	C	8.0	12.0	96.0	96.0	2.3	3.6	0.4										
902.78	S11	SB 150+18	S11	SB 150+26	C	8.0	12.0	96.0	96.0	2.3	3.6	0.4										
902.78	S11	SB 150+31	S12	SB 150+39	R	8.0	12.0	96.0	96.0						3.0	10.7	16					
902.79	S11	SB 150+61	S12	SB 150+39	L	8.0	12.0	96.0	96.0						3.0	10.7	16					
902.79	S12	SB 150+52	S12	SB 150+52	R	8.0	12.0	96.0	96.0						3.0	10.7	16					
902.79	S12	SB 150+52	S12	SB 150+60	L	8.0	12.0	96.0	96.0						3.0	10.7	16					
902.79	S12	SB 150+60	S13	SB 150+76	R	8.0	12.0	96.0	96.0					8.0	3.0	10.7	16					8.0
902.79	S12	SB 150+68	S13	SB 150+76	C	8.0	12.0	96.0	96.0	2.3	3.6	0.4										
902.79	S13	SB 150+86	S13	SB 150+99	C	13.0	12.0	156.0	156.0	3.8	5.8	0.6										
902.79	S13	SB 150+86	S13	SB 150+99	L	13.0	12.0	156.0	156.0						4.8	17.3	16	4				
902.80	S13	SB 150+91	S13	SB 150+99	R	8.0	12.0	96.0	96.0						3.0	10.7	16					
902.80	S13	SB 151+09	S1	SB 151+17	R	8.0	12.0	96.0	96.0						3.0	10.7	16					
902.81	S2	SB 151+66	S3	SB 152+16	R	50.0	12.0	600.0	600.0				36.0	50.0	18.5	66.7	8				36.0	50.0
902.81	S2	SB 151+66	S3	SB 152+16	C	50.0	12.0	600.0	600.0	14.6	22.5	2.3										
902.81	S2	SB 151+94	S3	SB 152+16	L	22.0	12.0	264.0	264.0				12.0		8.1	29.3	8	7			12.0	
902.71	N2	NB 146+22	N2	NB 146+30	L	8.0	12.0	96.0	96.0						3.0	10.7	16					
902.71	N2	NB 146+22	N2	NB 146+30	C	8.0	12.0	96.0	96.0						8.0	3.0	10.7	16				8.0
902.72	N3	NB 146+60	N3	NB 146+68	C	8.0	12.0	96.0	96.0						3.0	10.7	16					
902.75	N7	NB 148+15	N7	NB 148+23	R	8.0	12.0	96.0	96.0						3.0	10.7	16					
902.75	N8	NB 148+55	N8	NB 148+71	C	16.0	12.0	192.0	192.0	4.7	7.2	0.7										
902.75	N8	NB 148+55	N8	NB 148+63	R	8.0	12.0	96.0	96.0						3.0	10.7	16					
902.76	N9	NB 149+00	N9	NB 149+08	L	8.0	12.0	96.0	96.0						3.0	10.7	16					
902.78	N11	NB 149+75	N11	NB 149+33	L	8.0	12.0	96.0	96.0						3.0	10.7	16					
902.79	N13	NB 150+53	N13	NB 150+61	C	8.0	12.0	96.0	96.0	2.3	3.6	0.4										
902.80	N14	NB 150+92	N14	NB 151+06	C	14.0	12.0	168.0	168.0	4.1	6.3	0.7										
902.80	N1	NB 151+35	N1	NB 151+47	L	12.0	12.0	144.0	144.0				12.0		4.4	16.0	16					12.0
902.80	N1	NB 151+35	N1	NB 151+47	C	12.0	12.0	144.0	144.0	3.5	5.4	0.6										
902.82	N3	NB 152+01	N3	NB 152+16	L	15.00	12.00	180.00	180.00						5.6	20.0	8					

SEE PLAN ON DWG. CPR-16

CHECKED BY: J.KLEINMANN

DRAFTED BY: N.HOY

CHECKED BY: J.KLEINMANN



DESIGNED BY: P.AMICONE

DESIGN SUPERVISOR: D.MARSH

ALTERED ON:	AFFIXED ON: 2/5/2026
SIGNATURE: STAMP:	SIGNATURE: STAMP: 

IT IS A VIOLATION OF LAW FOR ANY PERSON, UNLESS THEY ARE ACTING UNDER THE DIRECTION OF A LICENSED PROFESSIONAL ENGINEER, ARCHITECT, LANDSCAPE ARCHITECT, OR LAND SURVEYOR, TO ALTER AN ITEM IN ANY WAY. IF AN ITEM BEARING THE STAMP OF A LICENSED PROFESSIONAL IS ALTERED, THE ALTERING ENGINEER, ARCHITECT, LANDSCAPE ARCHITECT, OR LAND SURVEYOR SHALL STAMP THE DOCUMENT AND INCLUDE THE NOTATION "ALTERED BY" FOLLOWED BY THEIR SIGNATURE, THE DATE OF SUCH ALTERATION, AND A SPECIFIC DESCRIPTION OF THE ALTERATION.

REVISIONS			
DATE	DESCRIPTION	BY	SYM.

 	TITLE OF PROJECT I-190 HIGHWAY REHABILITATION	CONTRACT NUMBER: TAN 26-14
	LOCATION OF PROJECT I-190 NIAGARA THRUWAY MP 90.7 TO MP 90.4.2	DATE: FEB. 2026
TITLE OF DRAWING CONCRETE PAVEMENT REPAIR TABLE	DRAWING NUMBER: CPRT-15	

THIS SHEET SUPERSEDES SHEET 266
IN ITS ENTIRETY

FULL DEPTH REPAIR																						
LOCATION						REPAIR DIMENSIONS																REMARKS
MILE MARKER	START SLAB	START STATION	END SLAB	END STATION	LANE	LENGTH (FT)	WIDTH (FT)	AREA (SF)	ITEM 304.00010018 (SF)	ITEM 404.1959 (TON)	ITEM 404.3789 (TON)	ITEM 407.01040009 (GAL)	ITEM 502.90010018 (LF)	ITEM 502.9310 (LF)	ITEM 510.00120018 (CY)	ITEM 510.20000018 (SY)	ITEM 510.81000018 (EA)	ITEM 510.81100018 (EA)	ITEM 510.91000018 (LF) (HINGE)	ITEM 510.91000018 (LF)	ITEM 510.91100018 (LF)	
903.54	S8	SB 190+16	S9	SB 190+25	C	9.0	12.0	108.0	108.0						3.3	12.0	16					
903.55	S11	SB 190+76	S13	SB 191+00	C	24.0	12.0	288.0	288.0	7.0	10.8	1.1				32.0						
903.55	S11	SB 190+76	S12	SB 190+91	L	15.0	12.0	180.0	180.0					15.0	5.6	20.0	16					15.0
903.56	S15	SB 191+43	S15	SB 191+51	R	8.0	12.0	96.0	96.0						3.0	10.7	16					
903.60	S26	SB 193+64	S26	SB 193+72	R	8.0	12.0	96.0	96.0					8.0	3.0	10.7	16					8.0
903.60	S26	SB 193+64	S26	SB 193+72	C	8.0	12.0	96.0	96.0						3.0	10.7	16	2				
903.60	S26	SB 193+64	S26	SB 193+72	L	8.0	12.0	96.0	96.0						3.0	10.7	16					
903.61	S27	SB 193+83	S28	SB 194+07	R	24.0	12.0	288.0	288.0				12.0		8.9	32.0	16		12.0			
903.61	S27	SB 193+83	S27	SB 193+91	C	8.0	12.0	96.0	96.0						3.0	10.7	16					
903.61	S28	SB 194+14	S1	SB 194+28	C	14.0	12.0	168.0	168.0					14.0	5.2	18.7	16					14.0
903.61	S28	SB 194+14	S1	SB 194+28	L	14.0	12.0	168.0	168.0						5.2	18.7	16					
903.53	N7	NB 189+81	N7	NB 189+89	L	8.0	12.0	96.0	96.0						3.0	10.7	16					
903.53	N7	NB 189+81	N7	NB 189+89	R	8.0	12.0	96.0	96.0						3.0	10.7	16					
903.35	N8	NB 180+04	N9	NB 190+18	L	14.0	12.0	168.0	168.0						5.2	18.7	16	4				
903.54	N8	NB 190+04	N9	NB 190+18	C	14.0	12.0	168.0	168.0						5.2	18.7	16					
903.54	N8	NB 190+04	N9	NB 190+18	R	14.0	12.0	168.0	168.0					14.0	5.2	18.7	16					14.0
903.54	N9	NB 190+31	N10	NB 190+39	C	8.0	12.0	96.0	96.0						3.0	10.7	16					
903.55	N11	NB 190+61	N11	NB 190+69	R	8.0	12.0	96.0	96.0						3.0	10.7	16					
903.55	N12	NB 190+94	N14	NB 191+16	C	22.0	12.0	264.0	264.0	6.4	9.9	1.0				29.3						
903.57	N17	NB 191+81	N17	NB 191+89	L	8.0	12.0	96.0	96.0						3.0	10.7	16					
903.57	N17	NB 191+81	N17	NB 191+89	C	8.0	12.0	96.0	96.0	2.3	3.6	0.4				10.7						
903.57	N17	NB 191+81	N17	NB 191+89	R	8.0	12.0	96.0	96.0					8.0	3.0	10.7	16					8.0
903.59	N23	NB 193+01	N23	NB 193+09	R	8.0	12.0	96.0	96.0						3.0	10.7	16					
903.60	N1	NB 193+41	N1	NB 193+49	C	8.0	12.0	96.0	96.0	2.3	3.6	0.4				10.7						
903.61	N3	NB 193+81	N3	NB 193+89	R	8.0	12.0	96.0	96.0						3.0	10.7	16					
903.62	N7	NB 194+57	N7	NB 194+64	C	14.5	12.0	174.0	174.0	4.2	6.5	0.7				19.3						
903.62	N7	NB 194+57	N7	NB 194+64	R	14.5	12.0	174.0	174.0						23.0	5.4	19.3	16				23.0

SEE PLAN ON DWG. CPR-22

CHECKED BY: J. KLEINMANN

DRAFTED BY: N. HOY

CHECKED BY: J. KLEINMANN

DESIGNED BY: P. AMICONE

DESIGN SUPERVISOR: D. MARSH

ALTERED ON:	AFFIXED ON: 2/5/2026
SIGNATURE: STAMP:	SIGNATURE: STAMP:

ITEM	DESCRIPTION	UNITS	ITEM	DESCRIPTION	UNITS
304.00010018	FINE GRADING OF EXISTING SUBBASE	SF	510.00120018	PORTLAND CEMENT CONCRETE (PCC) FOR FULL-DEPTH PAVEMENT REPAIRS -UNREINFORCED, PEM, FRICTION TYPE 2	CY
404.1959	19 F9 BINDER COURSE WMA, 50 SERIES COMPACTION	TON	510.20000018	PORTLAND CEMENT CONCRETE (PCC) PAVEMENT LIFT OUT	SY
404.3789	37.5 F9 BASE COURSE WMA, 80 SERIES COMPACTION	TON	510.81000018	DRILL AND ANCHOR DOWELS FOR PCC PAVEMENT REPAIRS	EA
407.01040009	NON-TRACKING TACK COAT	GAL	510.81100018	DRILL AND ANCHOR TIES FOR PCC PAVEMENT REPAIRS	EA
502.90010018	CLEAN AND FILL CRACKS AND JOINTS IN PORTLAND CEMENT CONCRETE(PCC) PAVEMENT, ASTM D 6690 TYPE IV	LF	510.91000018	TRANSVERSE JOINTS FOR PCC PAVEMENT REPAIRS	LF
502.9310	SEALING LONGITUDINAL JOINTS - HIGHWAY JOINT SEALER	LF	510.91100018	LONGITUDINAL JOINTS FOR PCC PAVEMENT REPAIRS	LF

IT IS A VIOLATION OF LAW FOR ANY PERSON, UNLESS THEY ARE ACTING UNDER THE DIRECTION OF A LICENSED PROFESSIONAL ENGINEER, ARCHITECT, LANDSCAPE ARCHITECT, OR LAND SURVEYOR, TO ALTER AN ITEM IN ANY WAY. IF AN ITEM BEARING THE STAMP OF A LICENSED PROFESSIONAL IS ALTERED, THE ALTERING ENGINEER, ARCHITECT, LANDSCAPE ARCHITECT, OR LAND SURVEYOR SHALL STAMP THE DOCUMENT AND INCLUDE THE NOTATION "ALTERED BY" FOLLOWED BY THEIR SIGNATURE, THE DATE OF SUCH ALTERATION, AND A SPECIFIC DESCRIPTION OF THE ALTERATION.

REVISIONS			
DATE	DESCRIPTION	BY	SYM.

	TITLE OF PROJECT I-190 HIGHWAY REHABILITATION	CONTRACT NUMBER: TAN 26-14
	LOCATION OF PROJECT I-190 NIAGARA THRUWAY MP 900.7 TO MP 904.2	DATE: FEB. 2026
	TITLE OF DRAWING CONCRETE PAVEMENT REPAIR TABLE	DRAWING NUMBER: CPRT-19

CHECKED BY: E. SWEET

DRAFTED BY: S. SCHUKRAFT

CHECKED BY: E. SWEET

DRAFTED BY: S. SCHUKRAFT

DESIGN SUPERVISOR: D. MARSH

PIER 1

EXPANSION JOINT OPENING TABLE	
SUPERSTRUCTURE TEMPERATURE (°F)	JOINT OPENING (IN.)
30	1 3/8
35	1 3/8
40	1 3/8
45	1 1/4
50	1 1/4
55	1 1/4
60	1 1/4
65	1 1/4
70	1 1/8
75	1 1/8
80	1 1/8
85	1 1/8
90	1 1/8
95	1
100	1
105	1
110	1

NOTES:
MIN. OPENING (IN.) = 1
MAX. OPENING / REQ. MIN. SEAL WIDTH (IN.) = 1.625
TOTAL MOVEMENT (IN.) = 0.625

PIER 2

EXPANSION JOINT OPENING TABLE	
SUPERSTRUCTURE TEMPERATURE (°F)	JOINT OPENING (IN.)
30	2
35	2
40	2
45	1 7/8
50	1 7/8
55	1 3/4
60	1 3/4
65	1 3/4
70	1 5/8
75	1 5/8
80	1 5/8
85	1 1/2
90	1 1/2
95	1 3/8
100	1 3/8
105	1 3/8
110	1 1/4

NOTES:
MIN. OPENING (IN.) = 1.25
MAX. OPENING / REQ. MIN. SEAL WIDTH (IN.) = 2.5
TOTAL MOVEMENT (IN.) = 1.25

PIER 3

EXPANSION JOINT OPENING TABLE	
SUPERSTRUCTURE TEMPERATURE (°F)	JOINT OPENING (IN.)
30	2 1/4
35	2 1/4
40	2 1/8
45	2 1/8
50	2 1/8
55	2
60	2
65	1 7/8
70	1 7/8
75	1 7/8
80	1 3/4
85	1 3/4
90	1 5/8
95	1 5/8
100	1 5/8
105	1 1/2
110	1 1/2

NOTES:
MIN. OPENING (IN.) = 1.5
MAX. OPENING / REQ. MIN. SEAL WIDTH (IN.) = 2.75
TOTAL MOVEMENT (IN.) = 1.25

PIER 4

EXPANSION JOINT OPENING TABLE	
SUPERSTRUCTURE TEMPERATURE (°F)	JOINT OPENING (IN.)
30	2 1/4
35	2 1/4
40	2 1/8
45	2 1/8
50	2 1/8
55	2
60	2
65	1 7/8
70	1 7/8
75	1 7/8
80	1 3/4
85	1 3/4
90	1 5/8
95	1 5/8
100	1 5/8
105	1 1/2
110	1 1/2

NOTES:
MIN. OPENING (IN.) = 1.5
MAX. OPENING / REQ. MIN. SEAL WIDTH (IN.) = 2.75
TOTAL MOVEMENT (IN.) = 1.25

PIER 5

EXPANSION JOINT OPENING TABLE	
SUPERSTRUCTURE TEMPERATURE (°F)	JOINT OPENING (IN.)
30	1 7/8
35	1 3/4
40	1 3/4
45	1 3/4
50	1 5/8
55	1 5/8
60	1 5/8
65	1 1/2
70	1 1/2
75	1 1/2
80	1 3/8
85	1 3/8
90	1 3/8
95	1 1/4
100	1 1/4
105	1 1/4
110	1 1/8

NOTES:
MIN. OPENING (IN.) = 1.125
MAX. OPENING / REQ. MIN. SEAL WIDTH (IN.) = 2.25
TOTAL MOVEMENT (IN.) = 1.125

PIER 6

EXPANSION JOINT OPENING TABLE	
SUPERSTRUCTURE TEMPERATURE (°F)	JOINT OPENING (IN.)
30	2 3/8
35	2 3/8
40	2 3/8
45	2 1/4
50	2 1/4
55	2 1/8
60	2 1/8
65	2
70	2
75	2
80	1 7/8
85	1 7/8
90	1 3/4
95	1 3/4
100	1 5/8
105	1 5/8
110	1 1/2

NOTES:
MIN. OPENING (IN.) = 1.5
MAX. OPENING / REQ. MIN. SEAL WIDTH (IN.) = 3
TOTAL MOVEMENT (IN.) = 1.5

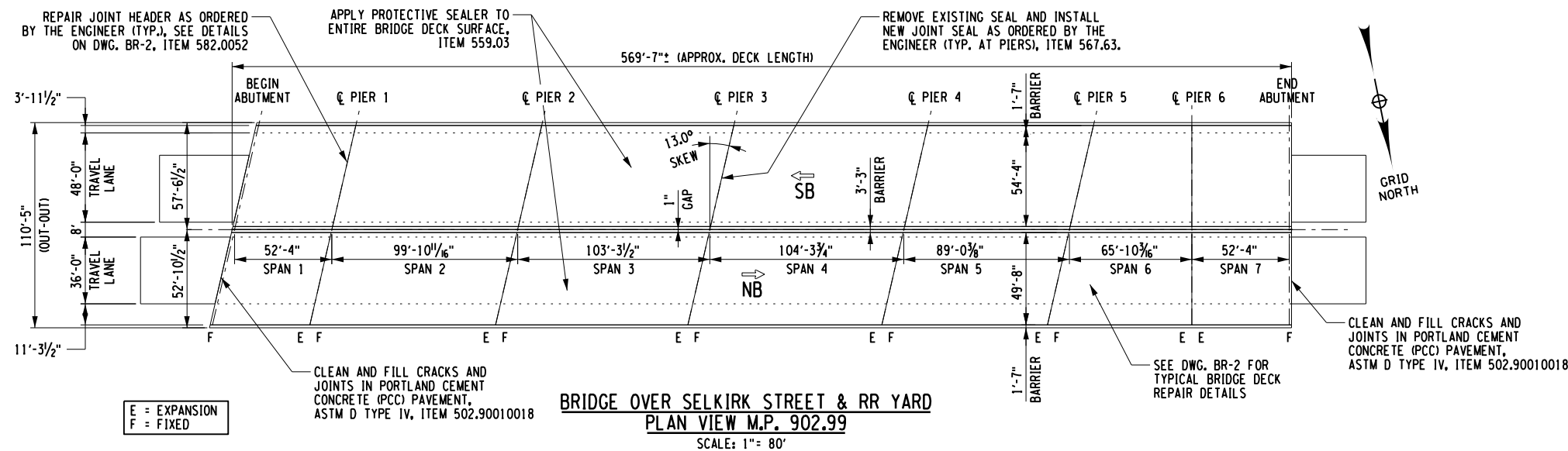

PROTECTIVE SEALING OF EXISTING BRIDGE DECKS ITEM 559.03				
BRIDGE OVER	LOCATION	NB AREA (SF)	SB AREA (SF)	TOTAL (SF)
BAILEY AVE & NS RR M.P. 901.88 BIN 5512199	SPAN 1 DECK	3,956	3,454	97,480
	SPAN 2 DECK	4,700	4,200	
	SPAN 3 DECK	3,395	3,539	
	SPAN 4 DECK	3,924	3,570	
	SPAN 5 DECK	3,902	0	
	SPAN 6 DECK	3,137	3,276	
	SPAN 7 DECK	6,494	5,959	
	SPAN 8 DECK	0	3,759	
	SPAN 9 DECK	3,262	3,806	
	SPAN 10 DECK	0	3,755	
	SPAN 11 DECK	4,788	3,837	
	SPAN 12 DECK	0	6,311	
	SPAN 13 DECK	11,348	3,108	
SELKIRK ST & RR YARD M.P. 902.99 BIN 5512239	SPAN 1 DECK	2,662	2,913	59,172
	SPAN 2 DECK	4,961	5,427	
	SPAN 3 DECK	5,130	5,612	
	SPAN 4 DECK	5,180	5,667	
	SPAN 5 DECK	4,421	4,837	
	SPAN 6 DECK	3,573	3,217	
	SPAN 7 DECK	2,661	2,911	
TOTAL				156,652

ALTERED ON: _____ AFFIXED ON: 2/6/2026

SIGNATURE: _____ STAMP: _____

BRIDGE OVER SELKIRK STREET & RR YARD
PLAN VIEW M.P. 902.99
SCALE: 1" = 80'

JOINT SEAL REMOVAL AND REPLACEMENT - ITEM 567.63: (NB & SB A.O.B.E.) 165'
REMOVAL AND REPLACEMENT OF STRUCTURAL CONCRETE - ITEM 582.0052: 128 SF
CLEAN AND FILL JOINT - ITEM 502.90010018: (NB) 105' + (SB) 115' = 220'
FOR JOINT SEAL DETAILS SEE DWG. NO. JD-7.
FOR TYPICAL CONCRETE REPAIR DETAILS, SEE DWG. NO. BR-2
JOINT SEAL OPENINGS AT LOCATIONS ORDERED BY THE ENGINEER SHALL BE DESIGNED BY THE CONTRACTOR AT THE LOCATIONS REQUIRED.

IT IS A VIOLATION OF LAW FOR ANY PERSON, UNLESS THEY ARE ACTING UNDER THE DIRECTION OF A LICENSED PROFESSIONAL ENGINEER, ARCHITECT, LANDSCAPE ARCHITECT, OR LAND SURVEYOR, TO ALTER AN ITEM IN ANY WAY. IF AN ITEM BEARING THE STAMP OF A LICENSED PROFESSIONAL IS ALTERED, THE ALTERING ENGINEER, ARCHITECT, LANDSCAPE ARCHITECT, OR LAND SURVEYOR SHALL STAMP THE DOCUMENT AND INCLUDE THE NOTATION "ALTERED BY" FOLLOWED BY THEIR SIGNATURE, THE DATE OF SUCH ALTERATION, AND A SPECIFIC DESCRIPTION OF THE ALTERATION.

REVISIONS			
DATE	DESCRIPTION	BY	SYM.

TITLE OF PROJECT: I-190 HIGHWAY REHABILITATION
LOCATION OF PROJECT: I-190 NIAGARA THRUWAY MP 900.7 TO MP 904.2
TITLE OF DRAWING: BRIDGE PLAN (8 OF 8)

CONTRACT NUMBER: TAN 26-14
DATE: FEB. 2026
DRAWING NUMBER: BP-8